



CHAPTER 3

Single Stage Amplifier

Outline

- 1. Common-Source Amplifier**
2. Common-Source Amp with Source Degeneration
3. Common-Drain Amplifier
4. Common-Gate Amplifier
5. Cascode Amplifier

Vision

- An important part of a designer's job is to use proper approximations so as to create a **simple mental picture** of a complicated circuit.
- The **intuition** thus gained makes it possible to formulate the behavior of most circuits **by inspection** rather than by lengthy calculations

Basic Concepts

- The input-output characteristic of an amplifier is generally a nonlinear function

$$y(t) \approx \alpha_0 + \alpha_1 x(t) + \alpha_2 x^2(t) + \cdots + \alpha_n x^n(t) \quad x_1 \leq x \leq x_2$$

- For a sufficiently narrow range of x

$$y(t) \approx \alpha_0 + \alpha_1 x(t), \quad \alpha_0: \text{operating point}, \alpha_1: \text{small signal gain}$$

- As $x(t)$ increases in magnitude, higher order terms manifest themselves, leading to nonlinear distortion.
- Input-output characteristic of a nonlinear system

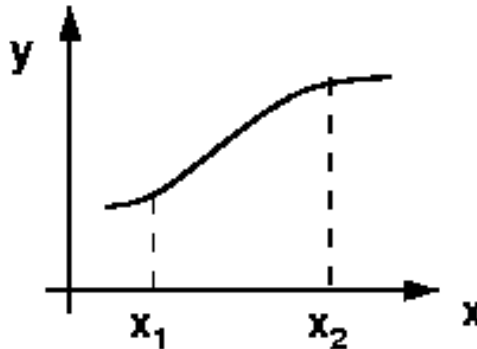

Analog Design Octagon

- Analog design octagon

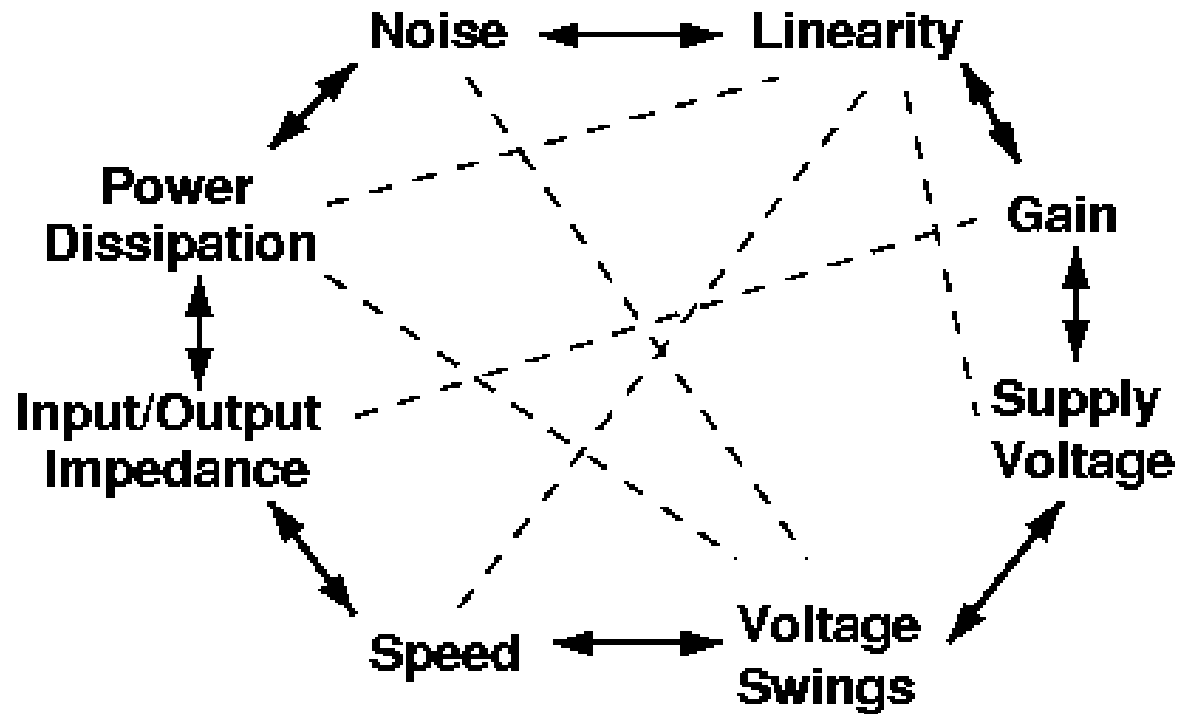

Common Source Stage (I)

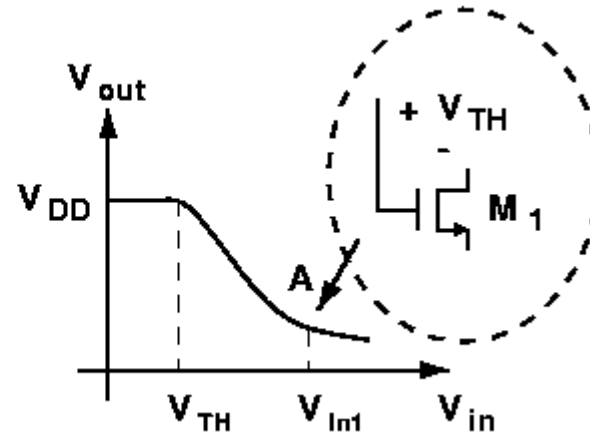
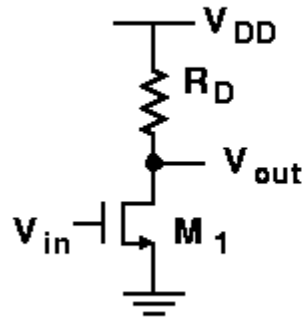

- M1 off

$$V_{in} \leq V_{TH} \Rightarrow V_{out} = V_{DD}$$

- M1 in the saturation region (Let $V_{TH} \leq V_{in} \leq V_{in1} \Rightarrow V_{in} - V_{TH} \leq V_{out}$)

– To find V_{in1}

$$V_{in1} - V_{TH} = V_{DD} - R_D \frac{1}{2} \mu_n C_{ox} \frac{W}{L} (V_{in1} - V_{TH})^2$$

- M1 in the triode region ($V_{in} > V_{in1}$)

$$V_{out} = V_{DD} - R_D \frac{1}{2} \mu_n C_{ox} \frac{W}{L} [2(V_{in1} - V_{TH})V_{out} - V_{out}^2]$$

Common Source Amplifier (II)

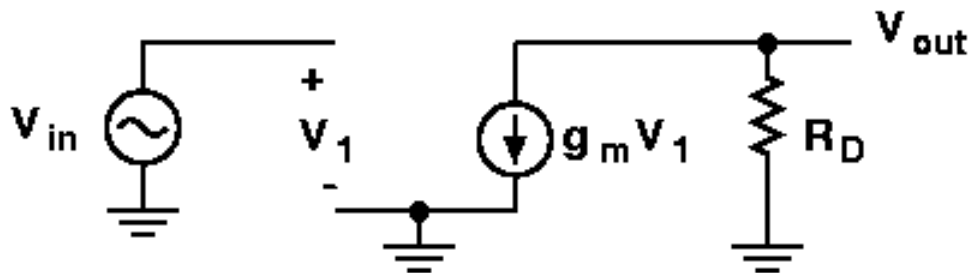
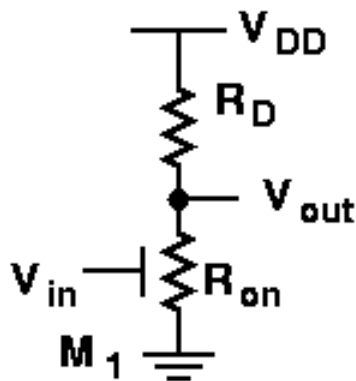

- Since the transconductance drops in the triode region, (the r_o also becomes smaller), we usually ensure that

$$V_{out} > V_{in} - V_{TH}$$

$$\text{As } V_{out} = V_{DD} - R_D \frac{1}{2} \mu_n C_{ox} \frac{W}{L} (V_{in1} - V_{TH})^2$$

$$\Rightarrow \frac{\partial V_{out}}{\partial V_{in}} = -R_D \mu_n C_{ox} \frac{W}{L} (V_{in1} - V_{TH}) = -g_m R_D$$

$$\Rightarrow A_v = -g_m R_D$$

- Since g_m itself varies with the input signal, the gain of the circuit changes substantially if the signal swing is large.

Common Source Amplifier (III)

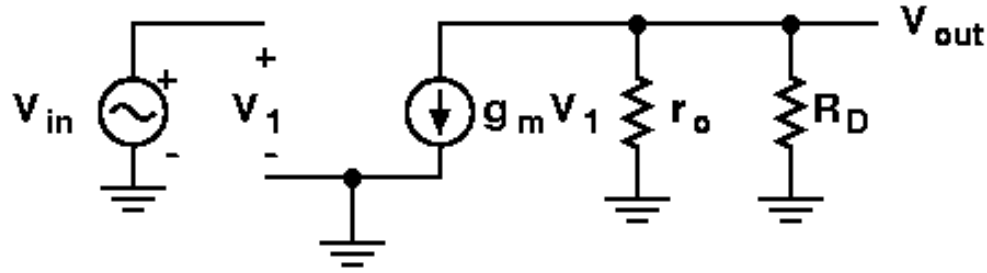

- To take channel length modulation effect into account :

$$V_{out} = V_{DD} - R_D \frac{1}{2} \mu_n C_{ox} \frac{W}{L} (V_{in1} - V_{TH})^2 (1 + \lambda V_{out})$$

- We have

$$\frac{\partial V_{out}}{\partial V_{in}} = -R_D \mu_n C_{ox} \frac{W}{L} (V_{in1} - V_{TH}) (1 + \lambda V_{out}) - R_D \frac{1}{2} \mu_n C_{ox} \frac{W}{L} (V_{in1} - V_{TH})^2 \lambda \frac{\partial V_{out}}{\partial V_{in}}$$

- As

$$I_D \approx \frac{1}{2} \mu_n C_{ox} \frac{W}{L} (V_{in1} - V_{TH})^2 \Rightarrow A_v = -R_D g_m - R_D I_D \lambda A_v \Rightarrow A_v = -\frac{g_m R_D}{1 + R_D \lambda I_D}$$

$$\lambda I_D = \frac{1}{r_o} \Rightarrow A_v = -g_m \frac{r_o R_D}{r_o + R_D} = -g_m (r_o \parallel R_D)$$

Design Trade-off

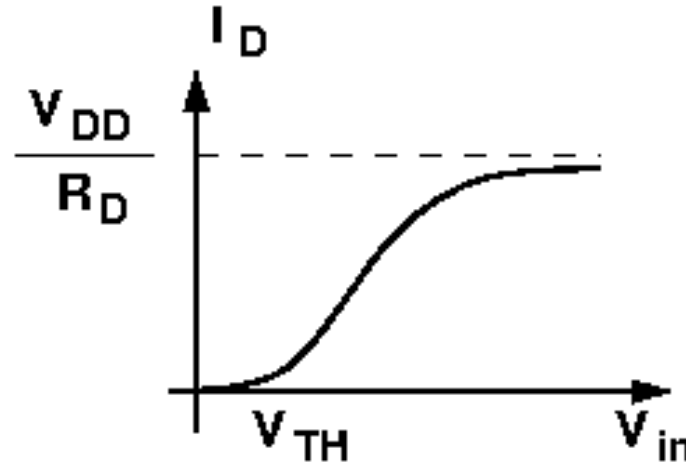

- To maximize gain

$$A_v = -\sqrt{2\mu_n C_{ox} \frac{W}{L} I_D} \frac{V_{RD}}{I_D} = -\sqrt{2\mu_n C_{ox} \frac{W}{L} \frac{V_{RD}}{\sqrt{I_D}}}$$

- Increase W/L \rightarrow greater device capacitance (*Gain* \leftrightarrow *BW*)
- Higher V_{RD} \rightarrow smaller voltage swing (*Gain* \leftrightarrow *Voltage swing*)
- Reduce I_D while V_{RD} is constant \rightarrow larger RC time constant at the output node (*Gain* \leftrightarrow *BW*)

Diode Connected Load

- In many CMOS technologies, it is difficult to fabricate resistors with tightly controlled values or a reasonable size. Replace R_D with a MOS transistor.

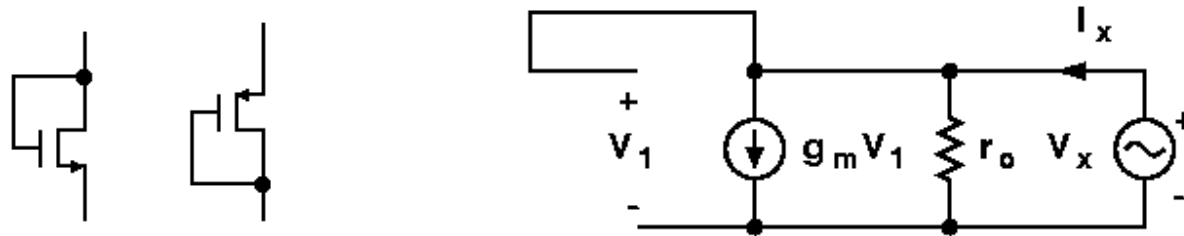

- Diode connected : gate and drain shorted $\rightarrow V_{DS} = V_{GS} > V_{GS} - V_{TH} \rightarrow$ the transistor always in saturation region.

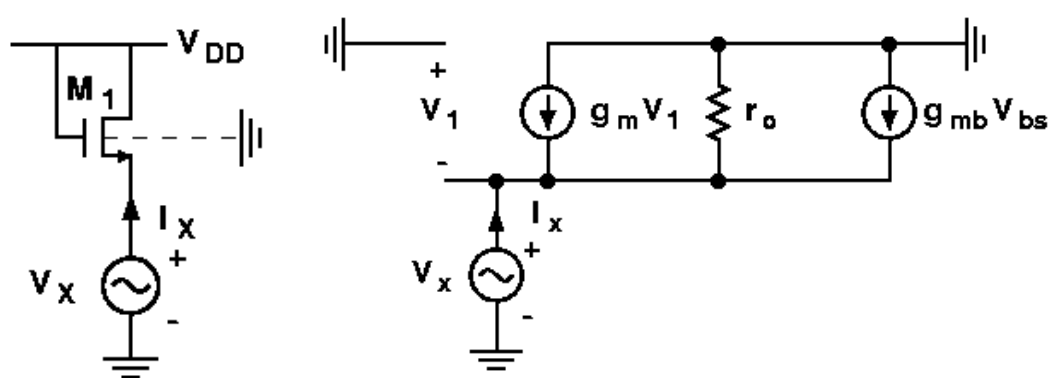

$$(g_m + g_{mb})V_x + \frac{V_x}{r_o} = I_x$$

$$\frac{V_x}{I_x} = \frac{1}{g_m + g_{mb} + r_o^{-1}}$$

$$R_L = \frac{1}{g_m + g_{mb}} \parallel r_o \approx \frac{1}{g_m + g_{mb}}$$

CS Stage + Diode Connected Load

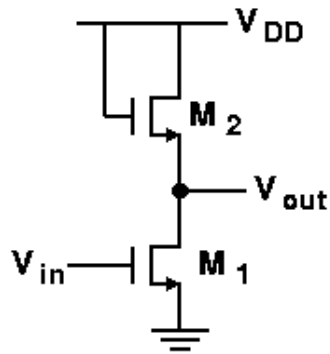

$$A_v = -g_{m1} \frac{1}{g_{m2} + g_{mb2}} = -\frac{g_{m1}}{g_{m2}} \frac{1}{1 + \eta} \quad \eta = \frac{g_{mb2}}{g_{m2}}$$

$$A_v = -\frac{\sqrt{2\mu_n C_{ox}(W/L)_1 I_{D1}}}{\sqrt{2\mu_n C_{ox}(W/L)_2 I_{D2}}} \frac{1}{1 + \eta} = -\frac{\sqrt{(W/L)_1}}{\sqrt{(W/L)_2}} \frac{1}{1 + \eta}$$

- If the variation of η with the output voltage is neglected, the gain is **independent of the bias current and voltages** (so long as M_1 stays in saturation).
- Input-output characteristics of a CS stage with diode connected load.
- Operated at point A.

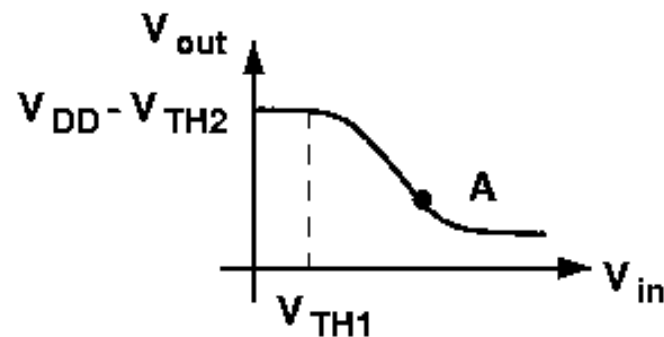

CS Stage + Diode-Connected PMOS

- The circuit is free from body effect.

$$A_v = -\sqrt{\frac{\mu_n (W/L)_1}{\mu_p (W/L)_2}} \quad A_v \approx -\frac{|V_{GS2} - V_{TH2}|}{V_{GS2} - V_{TH1}}$$

$$\mu_n \left(\frac{W}{L}\right)_1 (V_{GS1} - V_{TH1})^2 \approx \mu_p \left(\frac{W}{L}\right)_2 (V_{GS2} - V_{TH2})^2$$

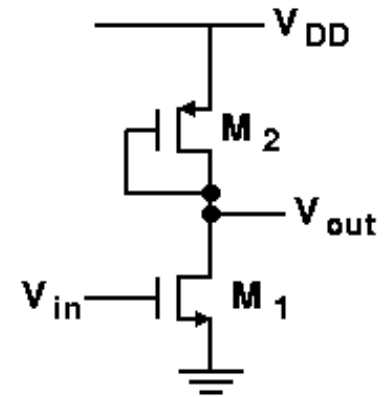

- Example :

If $A_v = 10$, $V_{GS1} - V_{TH1} = 200 \text{ mV}$, $\rightarrow V_{GS2} - V_{TH2} = 2 \text{ V}$, $V_{TH2} = 0.7 \text{ V} \rightarrow V_{GS2} = 2.7 \text{ V}$
 $\rightarrow V_{omax} = V_{DD} - V_{GS2} \rightarrow$ Trade-off between gain and output swing

- To take the effect of channel length modulation effect into account

$$A_v \approx -g_{m1} \left(\frac{1}{g_{m2}} \parallel r_{o1} \parallel r_{o2} \right)$$

CS Stage + Current Source Load

- For resistor or diode connected load, increasing the load resistance limits the output voltage swing \rightarrow CS stage with current source load.

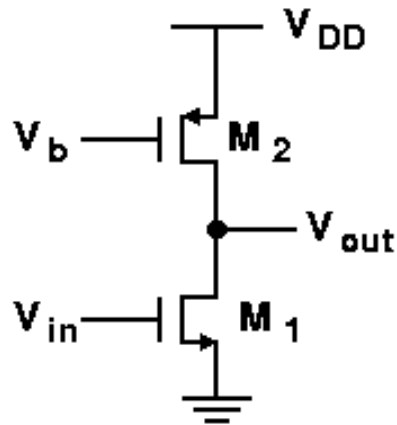

$$A_v = -g_{m1}(r_{O1} \parallel r_{O2})$$

$$|V_{DS2,\min}| = |V_{GS2} - V_{TH2}|$$

$$\lambda \propto 1/L \Rightarrow r_o \propto L/I_D$$

- The output bias voltage of the circuit needs a feedback loop to force V_{out} to a known value.
- If $A_v \uparrow \rightarrow L \uparrow \rightarrow W \uparrow$ (for constant I) $\rightarrow C_{load} \uparrow \rightarrow$ *Gain-Bandwidth Trade-off*
- Keep W constant, $L \uparrow \rightarrow V_{DS\min} \uparrow \rightarrow V_{out,swing} \downarrow$

CS Stage + Triode Load

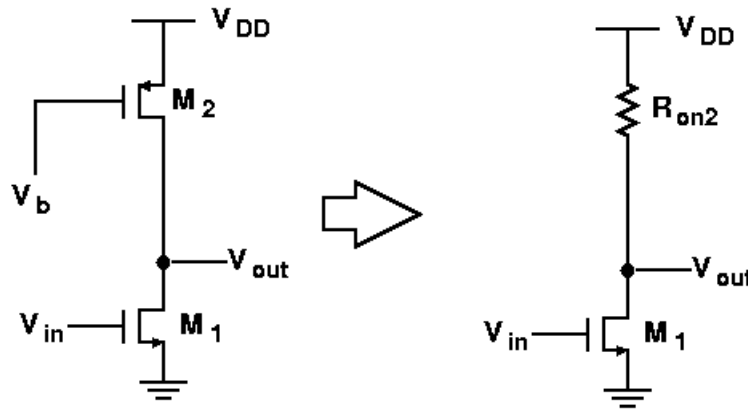

- The gate of M_2 is biased at a sufficiently low level, ensuring the load is in deep triode region for all output voltage swings.

$$V_{DD} - V_b - V_{TH} > V_{DD} - V_{out} \Rightarrow V_{out} - V_{TH} > V_b$$

$$R_{on2} = \frac{1}{\mu_p C_{ox} (W/L)_2 (V_{DD} - V_b - |V_{THP}|)}$$

- Consume less voltage headroom than diode connected devices.
- *Drawback*
 - R_{on2} depends on $\mu_p C_{ox}$, V_b , and V_{THP} , which vary with process and Temp.
 - Difficult to use.

Outline

1. Common-Source Amplifier
- 2. Common-Source Amp with Source Degeneration**
3. Common-Drain Amplifier
4. Common-Gate Amplifier
5. Cascode Amplifier

CS Stage + Source Degeneration (I)

- Common source Gain

$$V_{out} = -I_D R_D \Rightarrow A_v = \frac{\partial V_{out}}{\partial V_{in}} = -\frac{\partial I_D}{\partial V_{in}} R_D = -G_m R_D$$

- Improve the linearity of the gain amplifier
 - Higher linearity, Lower gain

G_m : equivalent transconductance of circuit

g_m : transconductance of MOS

$$\text{Let } I_D = f(V_{GS}) \Rightarrow G_m = \frac{\partial I_D}{\partial V_{in}} = \frac{\partial f}{\partial V_{GS}} \frac{\partial V_{GS}}{\partial V_{in}}$$

$$\text{For } V_{GS} = V_{in} - I_D R_S \Rightarrow \frac{\partial V_{GS}}{\partial V_{in}} = 1 - R_S \frac{\partial I_D}{\partial V_{in}}$$

$$G_m = \left(1 - R_S \frac{\partial I_D}{\partial V_{in}} \right) \frac{\partial f}{\partial V_{GS}} = (1 - R_S G_m) g_m \Rightarrow G_m = \frac{g_m}{1 + g_m R_S}$$

$$A_v = -G_m R_D = \frac{-g_m R_D}{1 + g_m R_S} = -\frac{R_D}{1/g_m + R_S} \Rightarrow \text{For } R_S \gg 1/g_m \quad G_m \approx 1/R_S$$

Linear!

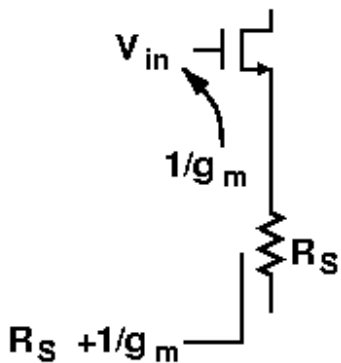
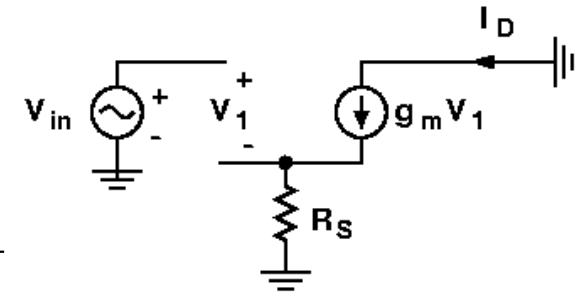
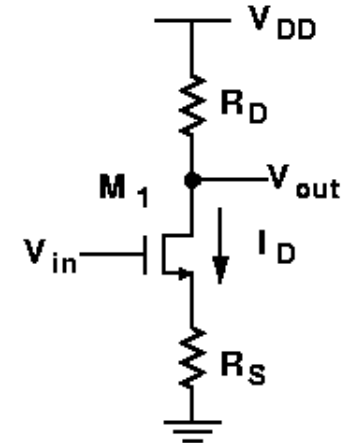

CS Stage + Source Degeneration (II)

- To take the body effect and channel length modulation effect into account

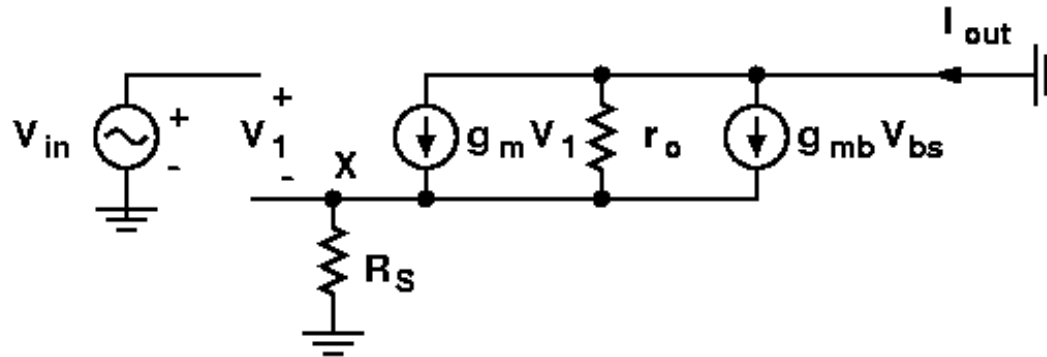

$$I_{out} = g_m V_1 - g_{mb} V_X - \frac{V_X}{r_o} = g_m (V_{in} - I_{out} R_S) + g_{mb} (-I_{out} R_S) - \frac{I_{out} R_S}{r_o}$$

$$G_m = \frac{I_{out}}{V_{in}} = \frac{g_m}{1 + (g_m + g_{mb}) R_S + R_S / r_o}$$

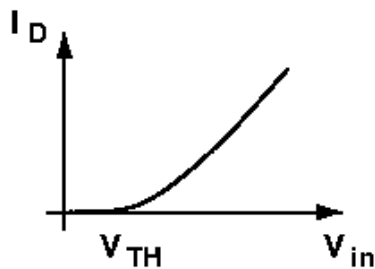

Common source amp

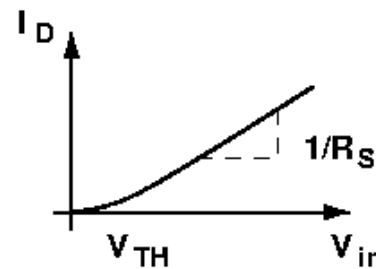
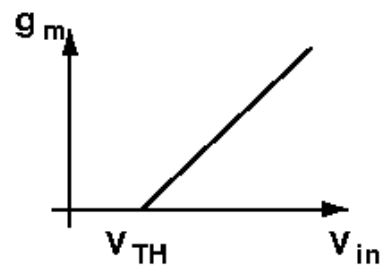

Common source amp + source degeneration

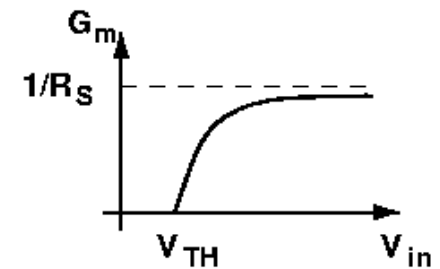

Formulate Gain by Inspection

- Magnitude of gain as the resistance seen at the drain node divided by the total resistance in the source path

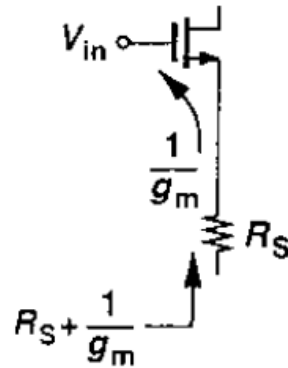

$$A_v = -\frac{R_D}{1/g_m + R_S}$$

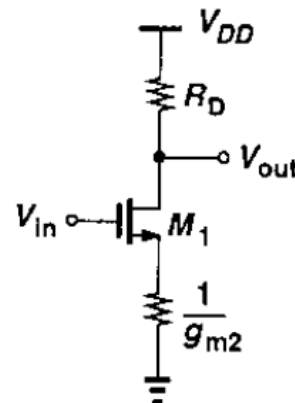
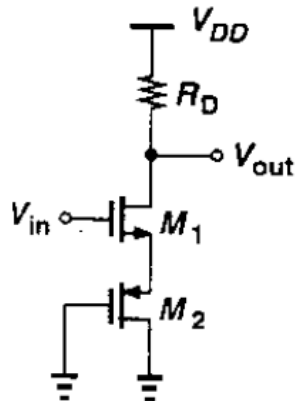

$$A_v = -\frac{R_D}{1/g_{m1} + 1/g_{m2}}$$

CS Stage + Source Degeneration (III)

- R_{out} of CS + Source degeneration

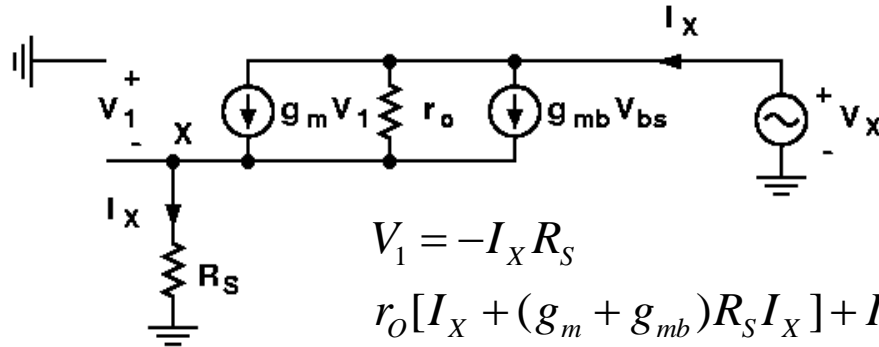

$$V_1 = -I_X R_S$$

$$r_o [I_X + (g_m + g_{mb}) R_S I_X] + I_X R_S = V_X$$

$$R_{out} = [1 + (g_m + g_{mb}) R_S] r_o + R_S = [1 + (g_m + g_{mb}) r_o] R_S + r_o$$

$$R_{out} \approx [1 + (g_m + g_{mb}) R_S] r_o$$

- By Inspection

$$\Delta V_{RS} = \Delta V \frac{\frac{1}{g_m + g_{mb}} \parallel R_S}{\frac{1}{g_m + g_{mb}} \parallel R_S + r_o}, \Delta I = \frac{\Delta V_{RS}}{R_S} = \Delta V \frac{1}{[1 + (g_m + g_{mb}) R_S] r_o + R_S}$$

$$\frac{\Delta V}{\Delta I} = [1 + (g_m + g_{mb}) R_S] r_o + R_S$$

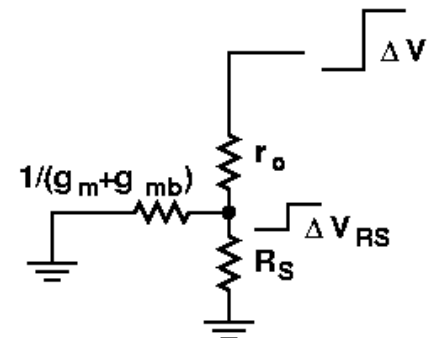
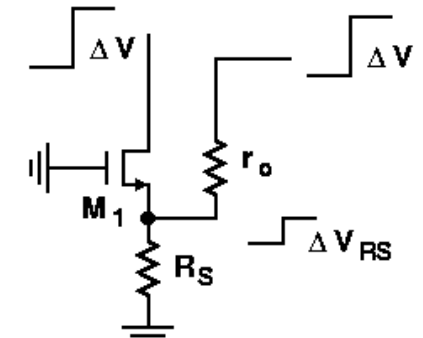
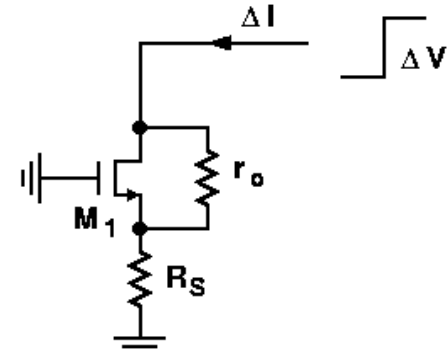

CS Stage + Source Degeneration (IV)

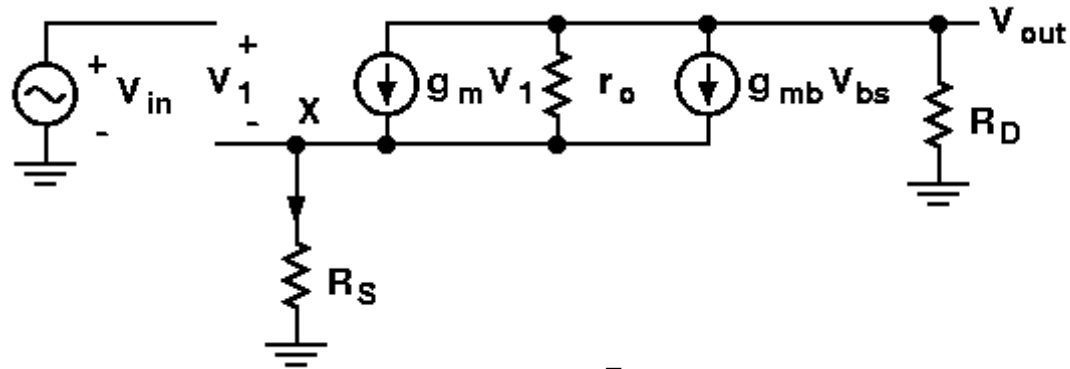

$$I_{r_o} = -\frac{V_{out}}{R_D} - (g_m V_1 + g_{mb} V_{bs}) = -\frac{V_{out}}{R_D} - \left[g_m \left(V_{in} + V_{out} \frac{R_S}{R_D} \right) + g_{mb} V_{out} \frac{R_S}{R_D} \right]$$

$$V_{out} = I_{r_o} r_o - \frac{V_{out}}{R_D} R_S = -\frac{V_{out}}{R_D} r_o - \left[g_m \left(V_{in} + V_{out} \frac{R_S}{R_D} \right) + g_{mb} V_{out} \frac{R_S}{R_D} \right] r_o - V_{out} \frac{R_S}{R_D}$$

- Voltage gain with r_o & g_{mb}

$$\begin{aligned} \frac{V_{out}}{V_{in}} &= -\frac{g_m r_o R_D}{R_D + R_S + r_o + (g_m + g_{mb}) R_S r_o} \\ &= -\frac{g_m r_o}{R_S + r_o + (g_m + g_{mb}) R_S r_o} \cdot \frac{R_D [R_S + r_o + (g_m + g_{mb}) R_S r_o]}{R_D + R_S + r_o + (g_m + g_{mb}) R_S r_o} \\ &= -G_{meff} R_O = -G_{meff} \{ R_D \parallel [R_S + r_o + (g_m + g_{mb}) R_S r_o] \} \end{aligned}$$

CS Stage + Source Degeneration (V)

- $I_0 = \text{constant}$, $I(R_S) = \text{constant}$, small-signal voltage drop across $R_S = 0$

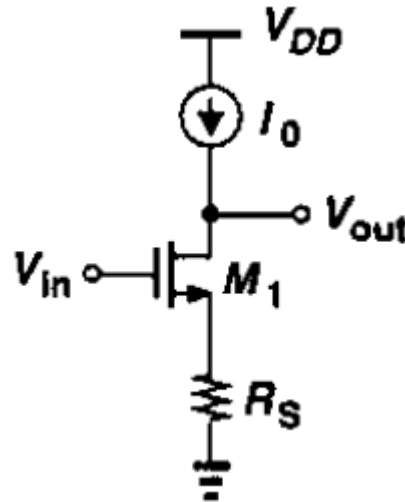

$$A_v = -\frac{g_m r_O}{R_S + [1 + (g_m + g_{mb})R_S]r_O} \{R_S + [1 + (g_m + g_{mb})R_S]r_O\}$$
$$= -g_m r_O = \text{intrinsic gain, independent of } R_S$$

Outline

1. Common-Source Amplifier
2. Common-Source Amp with Source Degeneration
- 3. Common-Drain Amplifier**
4. Common-Gate Amplifier
5. Cascode Amplifier

CD Stage: Source Follower (I)

- The source follower can operate as a voltage buffer – High input impedance, low output impedance.
- Gain ≈ 1 , but not equal to 1 even with $R_S = \text{infinity}$.

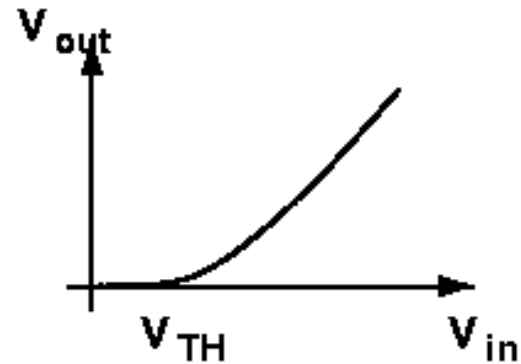
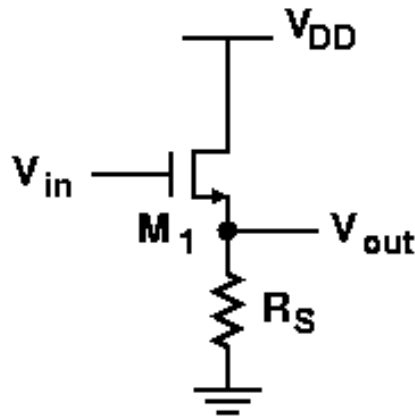

$$\frac{1}{2} \mu_n C_{ox} \frac{W}{L} (V_{in} - V_{TH} - V_{out})^2 R_S = V_{out}$$

$$\frac{\partial V_{out}}{\partial V_{in}} = \frac{\mu_n C_{ox} \frac{W}{L} (V_{in} - V_{TH} - V_{out}) R_S}{1 + \mu_n C_{ox} \frac{W}{L} (V_{in} - V_{TH} - V_{out}) R_S (1 + \eta)}$$

$$g_m = \mu_n C_{ox} \frac{W}{L} (V_{in} - V_{TH} - V_{out})$$

$$A_v = \frac{g_m R_S}{1 + (g_m + g_{mb}) R_S}$$

CD: Small-signal equivalent circuit

- Calculate the voltage gain by small-signal equivalent circuit of source follower with body effect

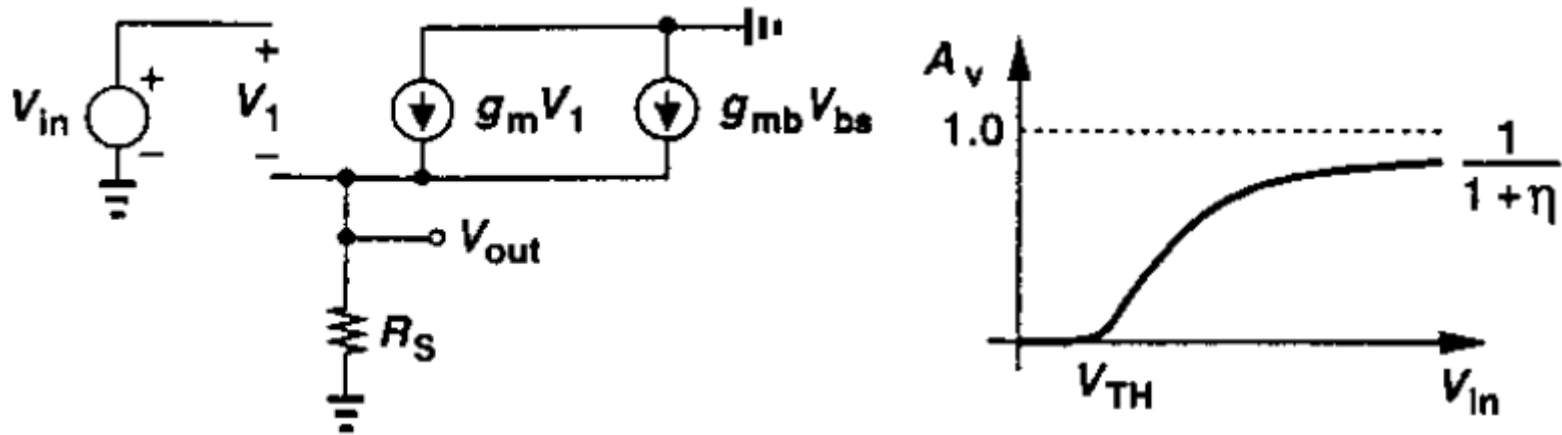

$$V_{in} - V_1 = V_{out}, \quad V_{bs} = -V_{out}, \quad g_m V_1 - g_{mb} V_{out} = V_{out} / R_S$$

$$A_v = \frac{V_{out}}{V_{in}} = \frac{g_m R_S}{1 + (g_m + g_{mb}) R_S}$$

$$V_{in} \uparrow \Rightarrow I_D \uparrow \Rightarrow g_m \uparrow \Rightarrow A_v \approx \frac{g_m}{g_m + g_{mb}} = \frac{1}{1 + \eta}$$

R_{out} of Source Follower

- Body effect decrease R_{out} of source follower

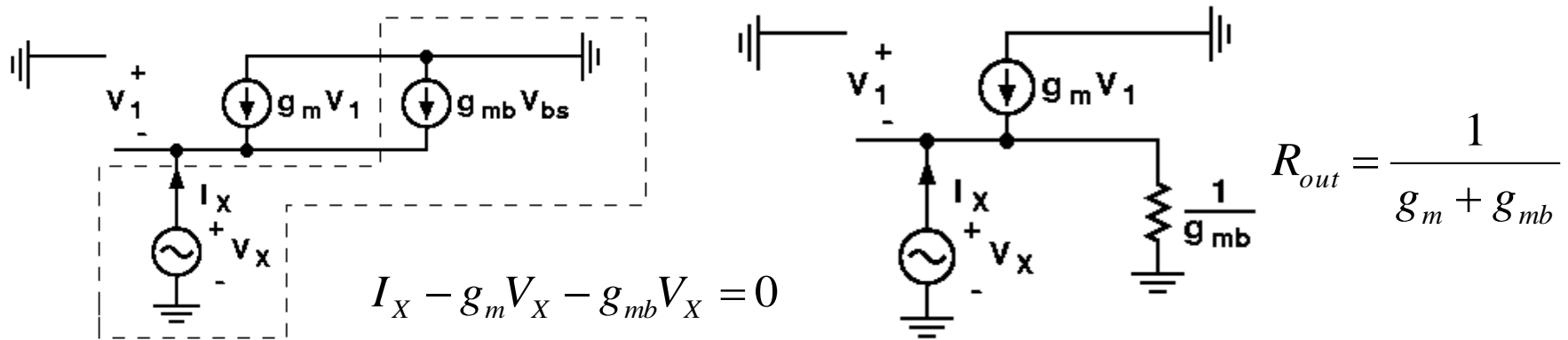

- Less-than-unity voltage gain of source follower with body effect

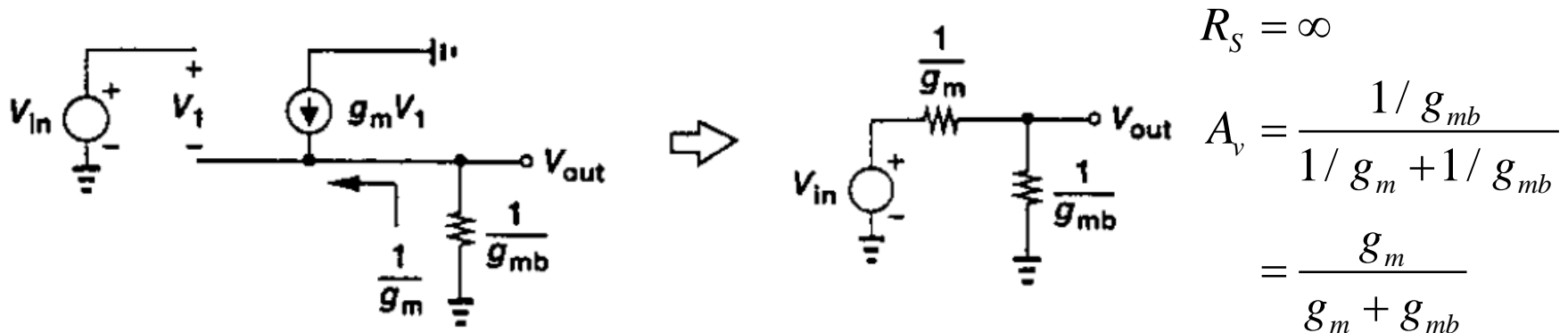

Source Follower with r_o

- Source follower with finite channel-length modulation

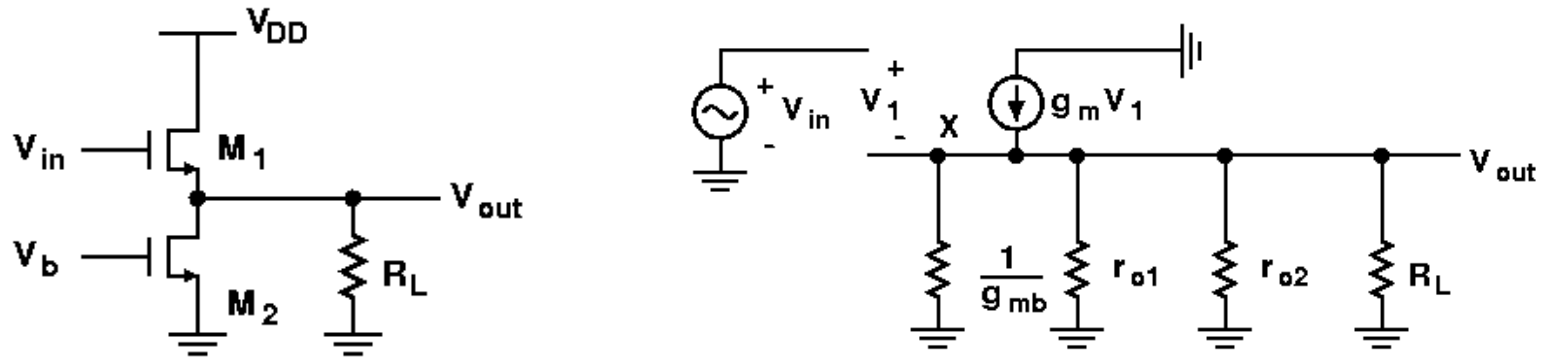

$$A_v = \frac{\frac{1}{g_{mb}} \parallel r_{o1} \parallel r_{o2} \parallel R_L}{\frac{1}{g_{mb}} \parallel r_{o1} \parallel r_{o2} \parallel R_L + \frac{1}{g_m}}$$

Source Follower Drawback

- Voltage headroom consumption due to level shift.
- Nonlinearity
 - Nonlinear dependence of V_{TH} upon the source potential.
 - r_o of the transistor also changes substantially with V_{DS} .
- PMOS source follower with no body effect

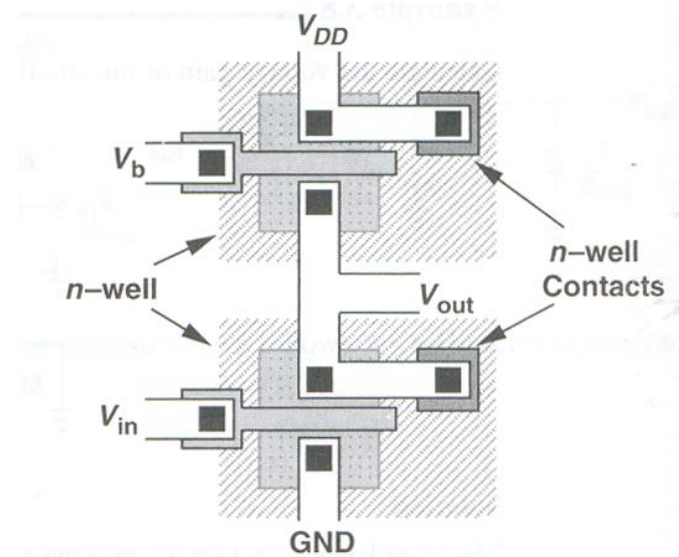
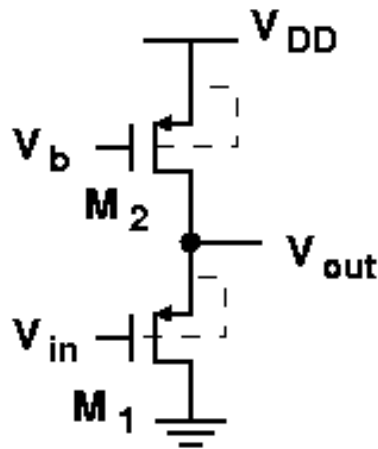

- Higher output impedance using PMOS source follower.

Outline

1. Common-Source Amplifier
2. Common-Source Amp with Source Degeneration
3. Common-Drain Amplifier
- 4. Common-Gate Amplifier**
5. Cascode Amplifier

CG: Common-Gate Stage

- If M_1 is saturated, the V_{out} can be expressed as

$$V_{out} = V_{DD} - \frac{1}{2} \mu_n C_{ox} \frac{W}{L} (V_b - V_{in} - V_{TH})^2 R_D$$

$$\frac{\partial V_{out}}{\partial V_{in}} = -\mu_n C_{ox} \frac{W}{L} (V_b - V_{in} - V_{TH}) \left(-1 - \frac{\partial V_{TH}}{\partial V_{in}} \right) R_D$$

$$\text{For } \frac{\partial V_{TH}}{\partial V_{in}} = \frac{\partial V_{TH}}{\partial V_{SB}} = \eta$$

$$\frac{\partial V_{out}}{\partial V_{in}} = \mu_n C_{ox} \frac{W}{L} (V_b - V_{in} - V_{TH}) (1 + \eta) R_D = g_m (1 + \eta) R_D$$

- Body effect increases the equivalent g_m of the stage.
- Body effect decreases the input impedance of CG.

$$Z_{in} = \frac{1}{g_m + g_{mb}} = \frac{1}{g_m (1 + \eta)}$$

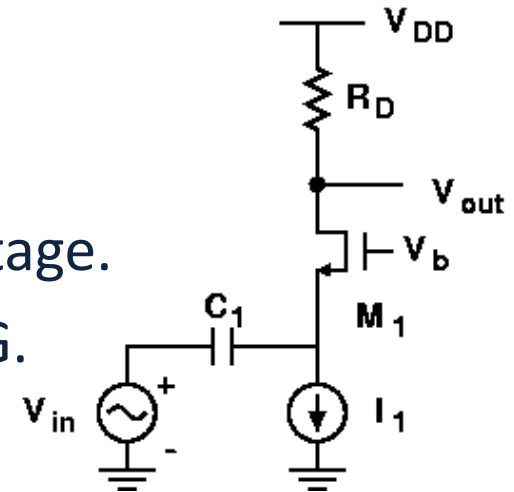
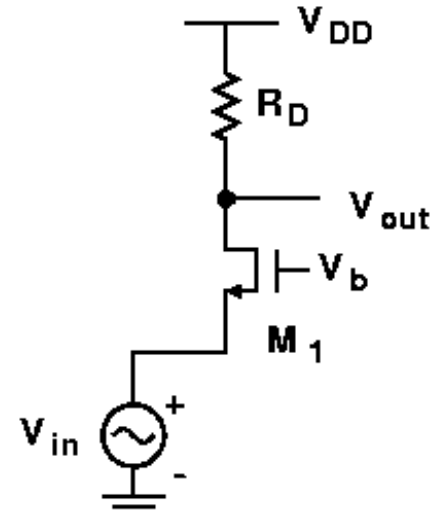

CG Stage- Input Impedance

- By taking into account both the output impedance of the transistor r_o , find the input impedance Z_{in} :

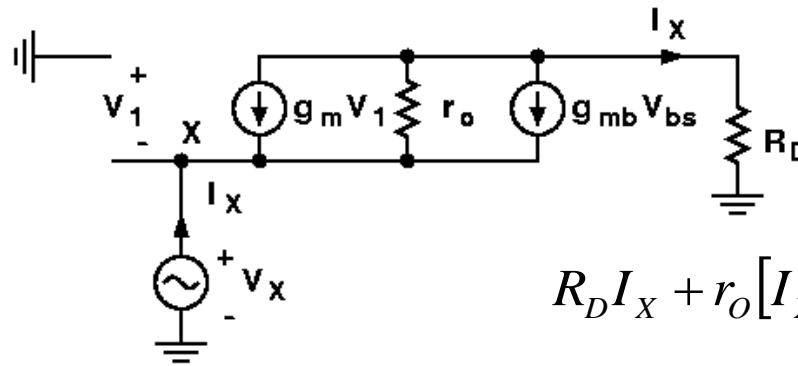
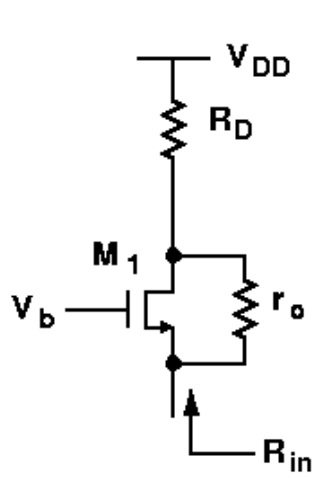

$$R_D I_X + r_o [I_X - (g_m + g_{mb}) V_X] = V_X$$

$$Z_{in} = \frac{V_X}{I_X} = \frac{R_D + r_o}{1 + (g_m + g_{mb}) r_o} \approx \frac{R_D}{(g_m + g_{mb}) r_o} + \frac{1}{g_m + g_{mb}}$$

- For $R_D = 0$, same as source follower

$$Z_{in} = \frac{V_X}{I_X} = \frac{r_o}{1 + (g_m + g_{mb}) r_o} = \frac{1}{g_m + g_{mb} + 1/r_o} = r_o \parallel \frac{1}{g_m} \parallel \frac{1}{g_{mb}}$$

- For $R_D = \infty$, $Z_{in} = \infty$

CG Stage- Output Impedance

- The output impedance is similar to that of a common source gain stage with source degeneration. R_S is the impedance of signal source.

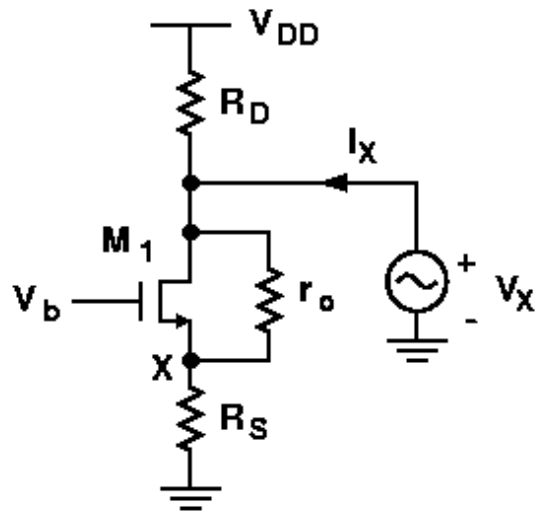

$$R_{out} = \{ [1 + (g_m + g_{mb})r_o]R_S + r_o \} \parallel R_D$$

CG Stage- Voltage gain

- Voltage gain is similar to CS + Source degeneration, it's slightly higher due to body effect

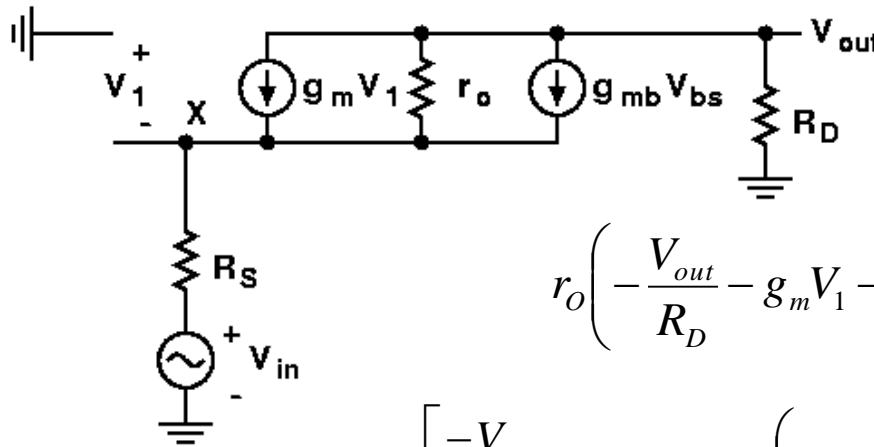
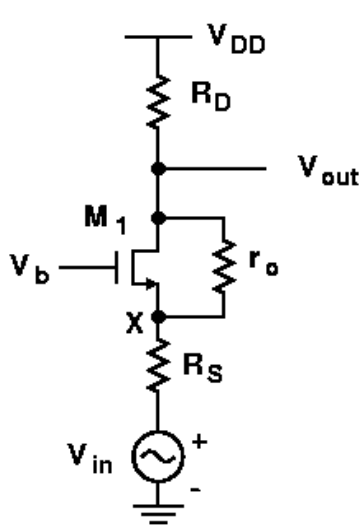

$$V_1 - \frac{V_{out}}{R_D} R_S + V_{in} = 0$$

$$r_o \left(-\frac{V_{out}}{R_D} - g_m V_1 - g_{mb} V_1 \right) - \frac{V_{out}}{R_D} R_S + V_{in} = V_{out}$$

$$r_o \left[\frac{-V_{out}}{R_D} - (g_m + g_{mb}) \left(V_{out} \frac{R_S}{R_D} - V_{in} \right) \right] - \frac{V_{out} R_S}{R_D} + V_{in} = V_{out}$$

$$\begin{aligned} \frac{V_{out}}{V_{in}} &= \frac{1 + (g_m + g_{mb})r_o}{r_o + (g_m + g_{mb})r_o R_S + R_S + R_D} R_D = \frac{1 + (g_m + g_{mb})r_o}{r_o + (g_m + g_{mb})r_o R_S + R_S} \frac{[r_o + (g_m + g_{mb})r_o R_S + R_S] R_D}{r_o + (g_m + g_{mb})r_o R_S + R_S + R_D} \\ &= \frac{1 + (g_m + g_{mb})r_o}{r_o + (g_m + g_{mb})r_o R_S + R_S} R_{out} \quad \left. \frac{V_{out}}{V_{in}} \right|_{CS+SD} = \frac{g_m r_o}{r_o + (g_m + g_{mb})r_o R_S + R_S} \frac{[r_o + (g_m + g_{mb})r_o R_S + R_S] R_D}{r_o + (g_m + g_{mb})r_o R_S + R_S + R_D} \end{aligned}$$

Outline

1. Common-Source Amplifier
2. Common-Source Amp with Source Degeneration
3. Common-Drain Amplifier
4. Common-Gate Amplifier
- 5. Cascode Amplifier**

CAS: Cascode Stage (I)

- Cascade of a CS stage and a CG stage \rightarrow a **high output impedance**.

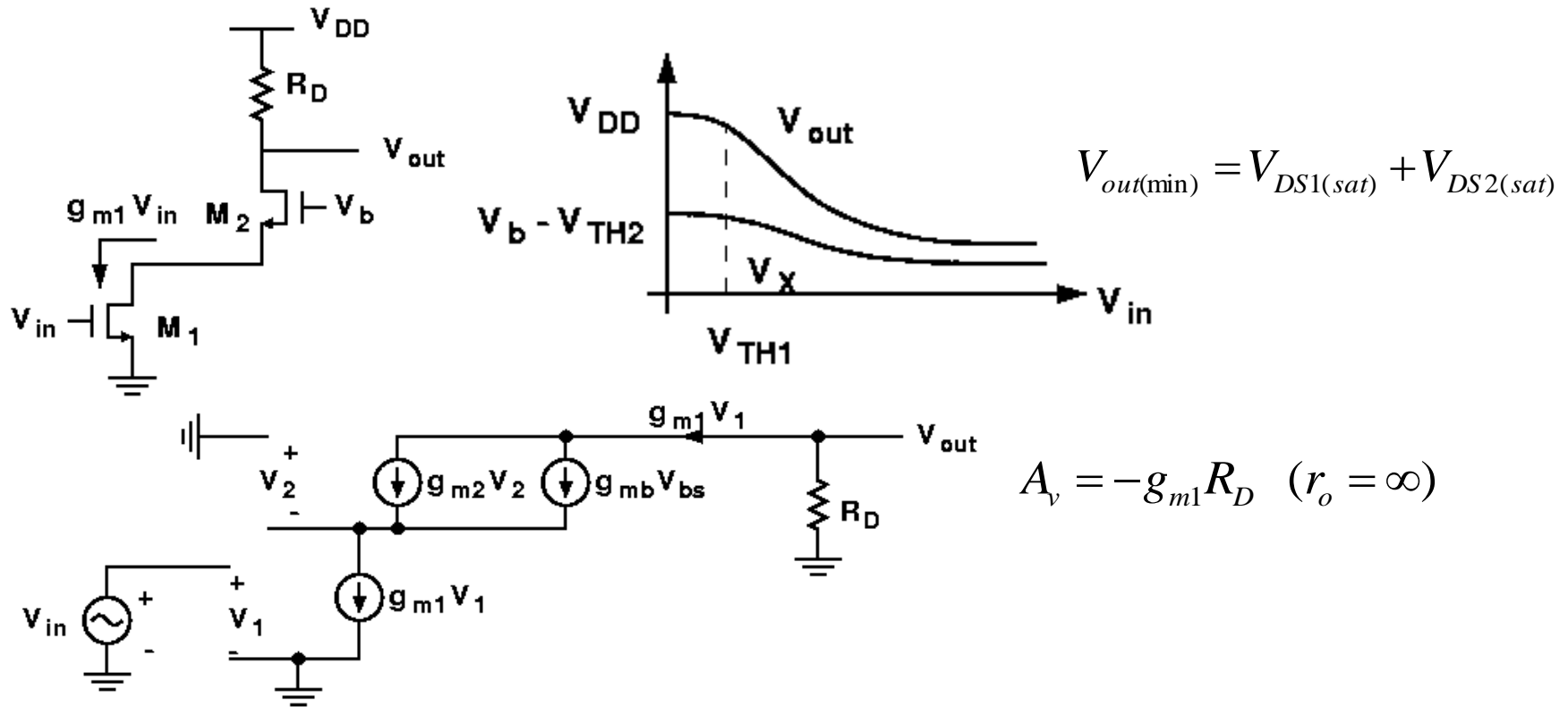

$$A_v = -g_{m1} R_D \quad (r_o = \infty)$$

- Without consideration of r_o , The voltage gain is independent of the transconductance and body effect of M_2 .

CAS: Cascode Stage (II)

- If both M_1 and M_2 operate in saturation.

$$G_m \approx g_{m1}$$

$$R_{out} = [1 + (g_{m2} + g_{mb2})r_{O2}]r_{O1} + r_{O2}$$

$$R_{out} \approx (g_{m2} + g_{mb2})r_{O2}r_{O1}$$

$$A_v = -(g_{m2} + g_{mb2})r_{O2}g_{m1}r_{O1}$$

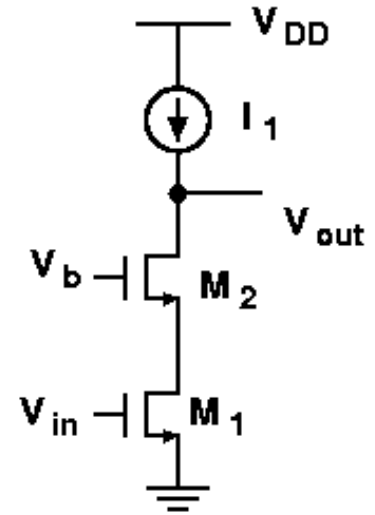

- The maximum voltage gain is roughly equal to the **square** of the intrinsic gain of the transistors

NMOS CAS Amp + PMOS CAS Load

- Cascode as a constant current source with high output impedance
- The maximum output swing is equal to

$$V_{out,swing} = V_{DD} - V_{DS1} - V_{DS2} - V_{SD3} - V_{SD4}$$

$$R_{out} = \left\{ \left[1 + (g_{m2} + g_{mb2})r_{O2} \right] r_{O1} + r_{O2} \right\} \\ \parallel \left\{ \left[1 + (g_{m3} + g_{mb3})r_{O3} \right] r_{O4} + r_{O3} \right\}$$

$$A_v \approx -g_{m1} \left[(g_{m2}r_{O2}r_{O1}) \parallel (g_{m3}r_{O3}r_{O4}) \right]$$

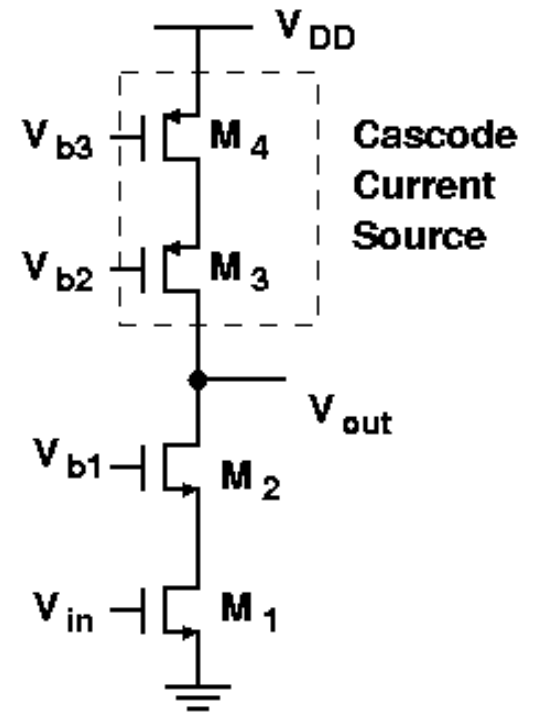

Folded Cascode

- A PMOS-NMOS combination.
- The total bias current in this case must be higher to achieve comparable performance.

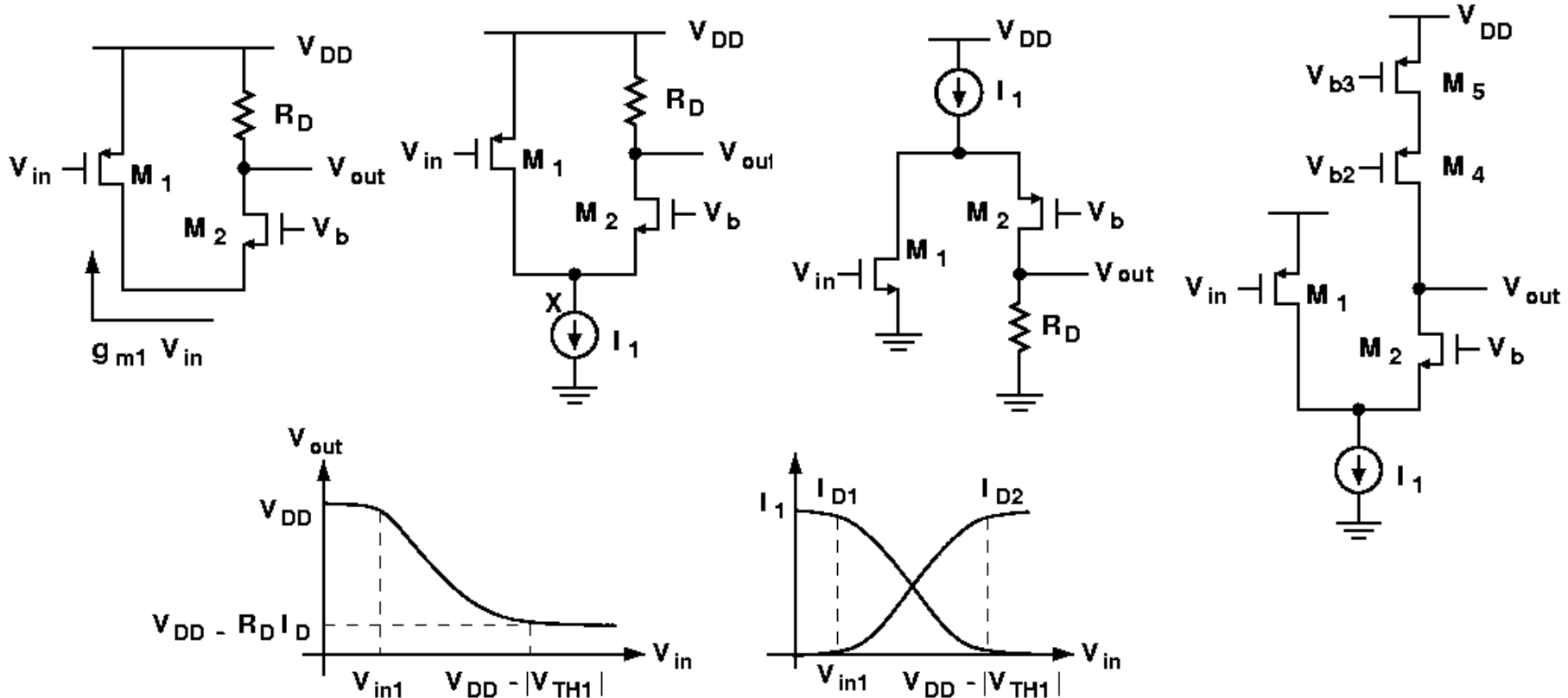

R_{out} of Folded-Cascode

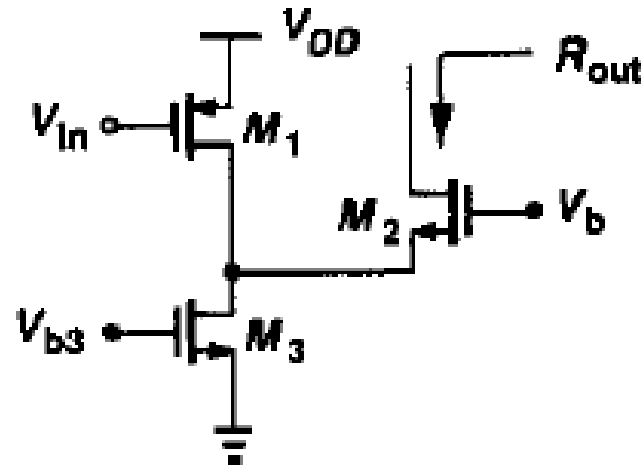

$$R_{out} = \left[1 + (g_{m2} + g_{mb2})r_{O2} \right] (r_{O1} \parallel r_{O3}) + r_{O2}$$

Designer's Intuition

- **Simulation is essential** because the behavior of short-channel MOSFET can't be predicted accurately by hand calculations.
- **Don't avoid** a **simple** and intuitive **analysis of the circuit** and skip the task of gaining inside, you can't interpret the simulate results intelligently.
- **Don't let the computer think for you!**