

1. Use composer and hspice to simulate the common source and source follower as shown at Fig. 1 with $V_{dd}=1.8V$. Every single one of MOS's c_{gtot} , c_{stot} , c_{dtot} , and c_{btot} can't have more than 70fF under your design. (40%)

- (a) Design a common source with gain $A1 > 110$ and plot the output noise's spectrum as shown at Fig. 1.
 - (a). Identify the corner frequency and pole of thermal noise. (5%)
- (b) Design a source follower with gain $A2 > 0.8$ and plot the output noise's spectrum as shown at Fig. 1.
 - (b). Identify the corner frequency and pole of thermal noise. (5%)
- (c) Compare between (a) and (b). Which one has higher output flicker noise? Which one has higher thermal noise's pole? Why? (10%)
- (d) Find the total output noise power of CS and SF base on integration of the spectrum. Which one is bigger? Why? (10%)
- (e) Find the total input referred noise power of CS and SF base on the result of (d) and gain you find. Which one is bigger? Why? (10%)

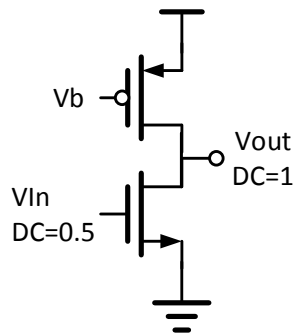

Fig. 1. (a)

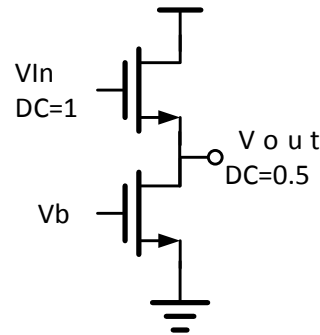

Fig. 1. (b)

2. Use the problem 1's design to perform two stage operation. (20%)

- (a) Connect CS and SF as shown at Fig. 2. (a) and find the total input referred noise power. (You are allowed to "slightly" adjust the bias condition to make sure the overall gain equals to $A1 \cdot A2$.) (1%)
- (b) Connect SF and CS as shown at Fig. 2. (b) and find the total input referred noise power. (You are allowed to "slightly" adjust the bias condition to make sure the overall gain equals to $A1 \cdot A2$.) (2%)
- (c) Comment on what makes the difference between (a) and (b). (16%)



Fig. 2. (a)

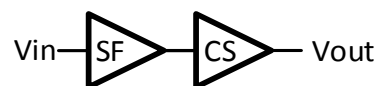

Fig. 2. (b)

✧ Before you start to simulate the .ac noise

1. Find the title "Flicker and Thermal noise Model Parameters" in "cic018.l".
2. Use the "replace all" to change value of the parameter into $KF=1E-29$.
3. Hint: use ".noise V(vout) vin 10000"

3. Design a differential to single-ended amplifier with $V_{DD}=1.8V$ as shown in Fig. 3. (40%)
- (a) Design a differential to single-ended amplifier to get voltage gain $A_v > 20dB$. (10%)
 - (b) Use the .op's parameters to calculate the pole of output node, mirrored node, and pseudo ground node. (20%)
 - (c) Use the .pz to check your calculation and simulate the bode plot. (10%)

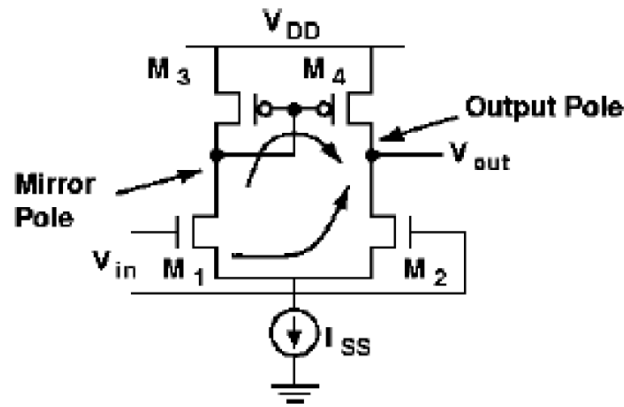

Fig. 3.

- ✧ *The following should be included in your report (a) schematic (b) HSPICE netlist & simulation file (c) waveform with cursor values (d) comments.*