

學號： _____

姓名： _____

For the active filter circuit along with its impedance model (where s is a shorthand notation for $j\omega$) as shown in the following figures,

- Write the node equations for \mathbf{V}_1 and \mathbf{V}_2 for the impedance model.
- Simplify these equations from (a) by using the ideal Op Amp assumptions in the impedance model, that is, $\mathbf{V}^- \approx \mathbf{V}^+$ and $\mathbf{I}^- = \mathbf{I}^+ \approx 0$.
- Find the transfer function $\mathbf{H}(j\omega) = \mathbf{V}_O(j\omega)/\mathbf{V}_{IN}(j\omega)$ for this circuit from (b).
- Indicate the frequency at which the peak occurs, the magnitude of the transfer function at the peak, and the Q of the resonance. Use the following numerical values:
 $C_1 = C_2 = 0.01 \mu\text{F}$, $R_1 = 10 \Omega$, $R_2 = 1 \text{ k}\Omega$
- Is this RC active filter a low-pass, high-pass, or bandpass filter?

(1) Circuit

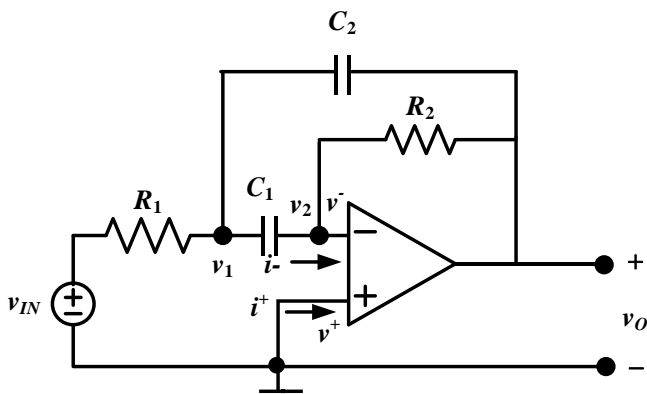

(2) Impedance model

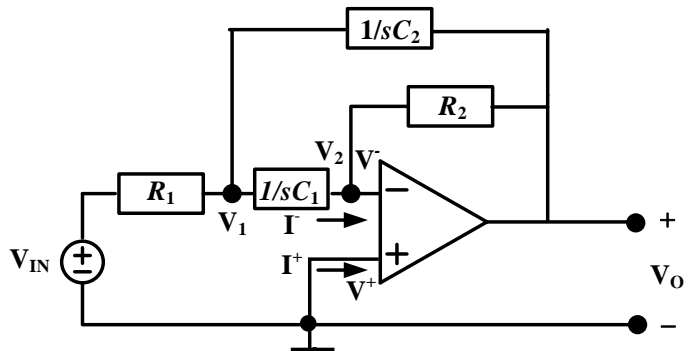

Solution:

(a)

Node \mathbf{V}_1 :

$$\frac{\mathbf{V}_1 - \mathbf{V}_{IN}}{R_1} + \frac{\mathbf{V}_1 - \mathbf{V}_O}{1/sC_2} + \frac{\mathbf{V}_1 - \mathbf{V}_2}{1/sC_1} = 0$$

$$\rightarrow \mathbf{V}_1 \left(\frac{1}{R_1} + sC_2 + sC_1 \right) = \frac{\mathbf{V}_{IN}}{R_1} + sC_2 \mathbf{V}_O + sC_1 \mathbf{V}_2$$

Node \mathbf{V}_2 :

$$\frac{\mathbf{V}_2 - \mathbf{V}_1}{1/sC_1} + \mathbf{i}^- + \frac{\mathbf{V}_2 - \mathbf{V}_O}{R_2} = 0$$

(b)

The ideal Op Amp assumptions, $\mathbf{V}_2 = \mathbf{V}^- = \mathbf{V}^+ \approx 0$ and $\mathbf{I}^- = \mathbf{I}^+ \approx 0$

Node \mathbf{V}_1 :

$$\mathbf{V}_1 \left(\frac{1}{R_1} + sC_2 + sC_1 \right) = \frac{\mathbf{V}_{IN}}{R_1} + sC_2 \mathbf{V}_o$$

Node \mathbf{V}_2 :

$$\mathbf{V}_1 = -\frac{\mathbf{V}_o}{sR_2C_1}$$

(c)

$$-\frac{\mathbf{V}_o}{sR_2C_1} \times \left(\frac{1}{R_1} + sC_2 + sC_1 \right) = \frac{\mathbf{V}_{IN}}{R_1} + sC_2 \mathbf{V}_o$$

$$\rightarrow \frac{\mathbf{V}_o}{\mathbf{V}_{IN}} = -\frac{sR_2C_1}{1 + s(R_1C_1 + R_1C_2) + s^2R_1R_2C_1C_2}$$

$$\rightarrow \frac{\mathbf{V}_o}{\mathbf{V}_{IN}} = -\frac{s/R_1C_2}{s^2 + s\left(\frac{C_1 + C_2}{R_2C_1C_2}\right) + \frac{1}{R_1R_2C_1C_2}}$$

(d)

Find quality factor $Q = \frac{\omega_0}{2\alpha}$

$$\Delta\omega = 2\alpha = \frac{C_1 + C_2}{R_1C_1C_2}$$

$$\alpha = \frac{C_1 + C_2}{2R_2C_1C_2} = \frac{2 \times 0.01 \times 10^{-6}}{2 \times 1000 \times (0.01 \times 10^{-6})^2} = 10^5$$

$$\omega_0 = \sqrt{\frac{1}{R_1R_2C_1C_2}} = \sqrt{\frac{1}{10 \times 1000 \times (0.01 \times 10^{-6})^2}} = 10^6$$

$$Q = \frac{\omega_0}{2\alpha} = \frac{10^6}{2 \times 10^5} = 5$$

(e)

bandpass filter

(a) Node $\mathbf{V}_1 =$ _____,

Node $\mathbf{V}_2 =$ _____,

(b) Node $\mathbf{V}_1 =$ _____,

Node $\mathbf{V}_2 =$ _____,

(c) $\mathbf{H}(j\omega) =$ _____,

(d) $\omega_0 =$ _____, $Q =$ _____

(e) _____.