

EE2210 Electric Circuits, Spring 2017
Practice problems solution (Lecture11-Lecture14)

1.

ANS:

$$(8 + j7) = 10.63e^{41.18^\circ j}$$

$$(0.3 - j0.1) = 0.316e^{-18.43^\circ j}$$

$$\text{MAG} = 16.8$$

$$\text{PHASE} = 13.75 \text{ deg}$$

2.

ANS:

a)

$$5.83e^{j59^\circ} \cdot 4e^{j50^\circ} \cdot 7e^{-j20^\circ} = 163.26e^{j89^\circ} \rightarrow 2.84 + j163$$

b)

$$10e^{j70^\circ} \rightarrow 3.42 + j9.4$$

3.

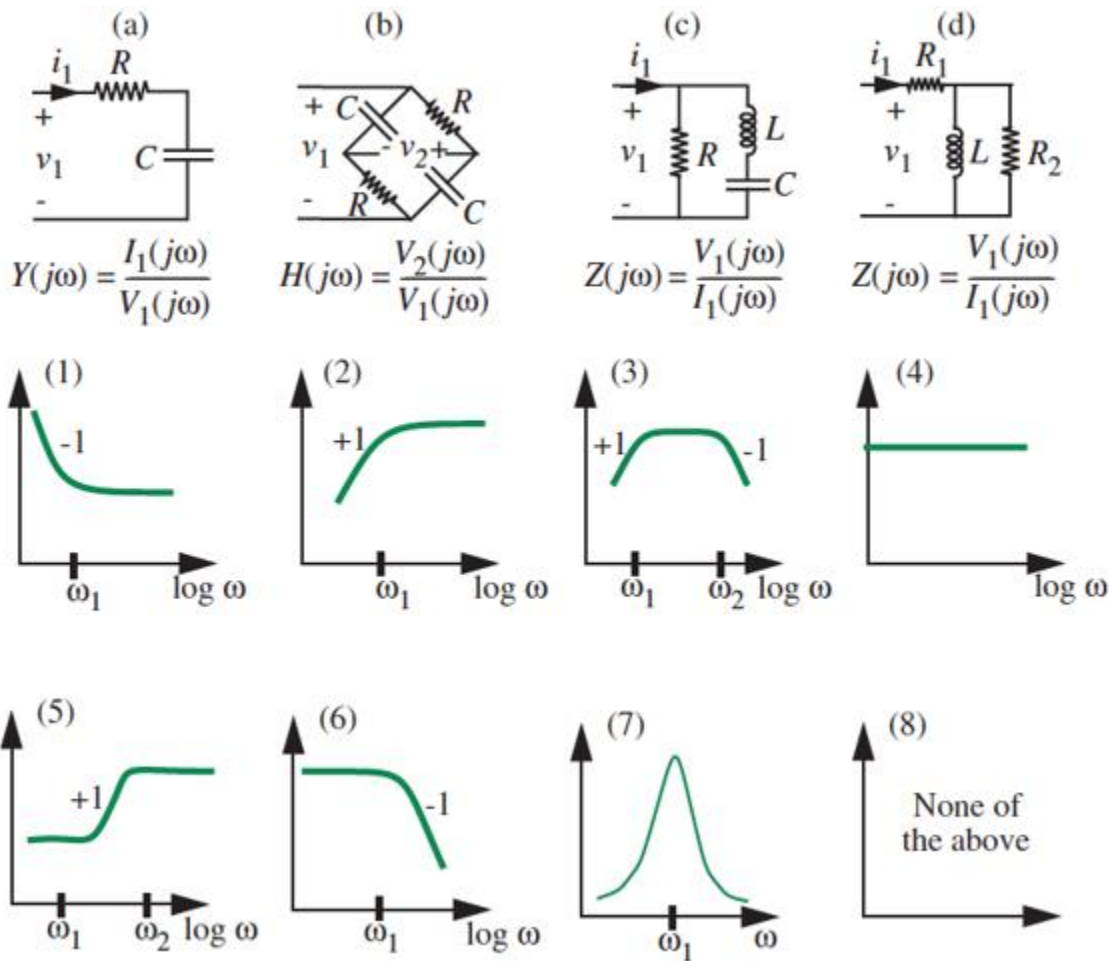

ANS: (a)2(b)4(c)8(d)5

4.

(b)

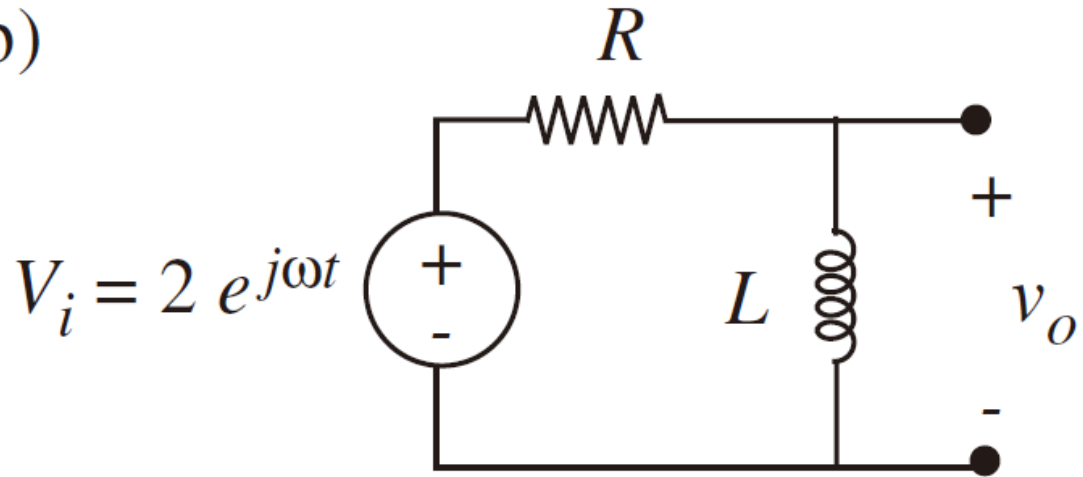

ANS:

$$\frac{V_o}{V_i} = \frac{L_s}{L_s + R} = \frac{\omega L}{\sqrt{(\omega L)^2 + R^2}} e^{j\phi}$$

$$\phi = \tan^{-1}\left(\frac{R}{\omega L}\right)$$

5.

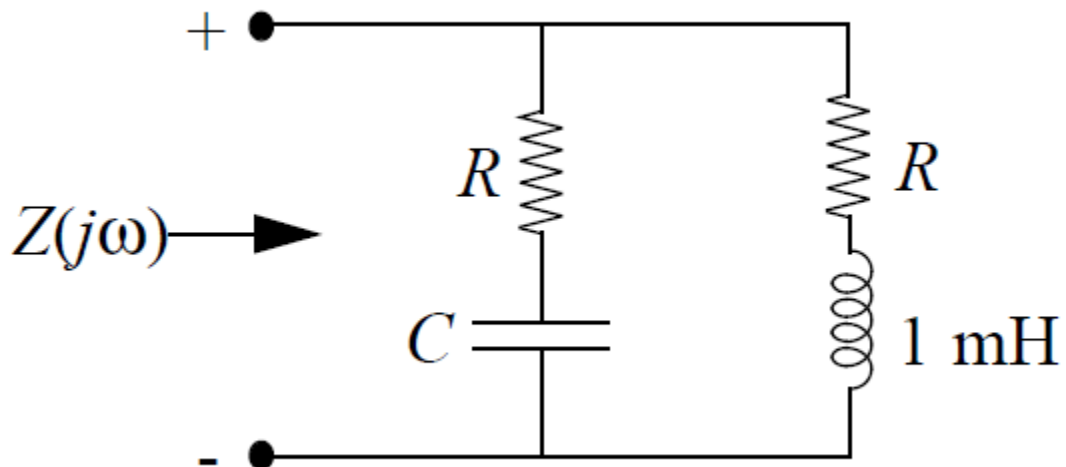

ANS:

$$Z = \frac{(R + \frac{1}{C_s})(R + L_s)}{2R + \frac{1}{C_s} + L_s} = \frac{R(LCs^2 + (\frac{L}{R} + RC)s + 1)}{LCs^2 + 2RCs + 1}$$

In order for Z to always be purely real,

$$\left(\frac{L}{R} + RC\right) = 2RC$$

$$L = R^2C$$

Then

$$Z = R = 2000$$

Independent of ω .

$$0.001 = 2000^2 C$$

$$C = 2.5 \cdot 10^{-10} \text{ Farads}$$

ANS: $R = 2000$ and $C = 2.5 \cdot 10^{-10} \text{ Farads}$

6.

ANS:

$$H(s) = \frac{1}{LCs^2 + RCs + 1} = \frac{1}{(1 - \omega^2 LC) + j\omega RC}$$

7.

ANS:

$$V_{rms} = \sqrt{\frac{1}{T} \int_0^T V^2 dt} = \sqrt{\frac{1}{T} \int_0^T \left(V_m \sin\left(\frac{2\pi}{T}t\right)\right)^2 dt} = \sqrt{\frac{V_m^2}{T} \int_0^T \sin^2\left(\frac{2\pi}{T}t\right) dt}$$

$$= \sqrt{\frac{V_m^2}{T} \frac{T}{2\pi} \int_0^T \sin^2\left(\frac{2\pi}{T}t\right) d\frac{2\pi}{T}t}$$

$$= \sqrt{\frac{V_m^2}{T} \frac{T}{2\pi} \int_0^T \frac{1 - \cos\left(2 * \frac{2\pi}{T}t\right)}{2} d\frac{2\pi}{T}t}$$

$$= \sqrt{\frac{V_m^2}{2\pi} \left[\frac{2\pi}{T}t - \frac{\sin\left(2 * \frac{2\pi}{T}t\right)}{4}\right]_0^{T/2}} = \sqrt{\frac{V_m^2}{2\pi} \left[\frac{\pi}{2}\right]} = \frac{V_m}{2}$$

請注意積分項的變數變換!

Note:

$$\sin^2(x) = \frac{1 - \cos(2x)}{2}$$

8.

ANS:

$$\omega = 50$$

$$Z = R + j\omega L + \frac{1}{j\omega C} = 4 + j * 50 * 0.24 - j \frac{1}{50 * 0.0025} = 5.66 \angle 45^\circ \Omega$$

$$I_0 = \frac{V}{Z} = \frac{0.1 \angle -90^\circ}{5.66 \angle 45^\circ} = 17.67 \angle -135^\circ \text{ mA}$$

$$i_0 = 17.67 \cos(50t - 135^\circ) \text{ mA}$$

9.

ANS:

(a)

$$Z_{ab} = j\omega L + R \parallel \left(\frac{1}{j\omega C} \right) = j\omega L + \frac{-\frac{jR}{\omega C}}{R - \frac{j}{\omega C}} = j\omega L + \frac{-jR}{\omega CR - j} = j\omega L + \frac{-jR(\omega CR + j)}{(\omega CR)^2 + 1}$$

Pure resistive $\rightarrow \text{Im}(Z_{ab}) = 0$

$$\therefore \omega L - \frac{\omega CR^2}{(\omega CR)^2 + 1} = 0 \rightarrow \omega^2 = \frac{\left(\frac{CR^2}{L}\right) - 1}{(CR)^2} = 900 * 10^8$$

$$\omega = 300 \text{ krad/s}$$

(b)

$$Z_{ab}(300 * 10^3) = j48 + \frac{100(-j133.33)}{100 - j133.33} = 64 \Omega$$

10.

ANS:

$$a) H(j\omega) = \frac{v_o}{v_i} = \frac{1/sC \parallel R_L}{R + 1/sC \parallel R_L} = \frac{R_L}{sRCR_L + (R + R_L)}$$

$$b) |H(j\omega)| = \frac{R_L}{\sqrt{\omega R C R_L^2 + (R + R_L)^2}} \quad |H(j\omega)| \text{ is maximum at } \omega = 0$$

$$c) |H(j\omega)|_{\max} = \frac{R_L}{R + R_L}$$

$$d) |H(j\omega)| = \frac{R_L}{\sqrt{2}(R + R_L)} = \frac{1/RC}{\sqrt{\omega_c^2 + [(R + R_L)/RR_L C]^2}} \quad \omega_c = \frac{1}{RC} \left(1 + \left(\frac{R}{R_L}\right)\right)$$

$$e) \omega_c = \frac{1}{(10^3)(10^{-7})} \left[1 + \left(\frac{10^3}{10^4}\right)\right] = 10000(1 + 0.1) = 11000 \frac{\text{rad}}{\text{s}}$$

$$H(j0) = \frac{10000}{11000} = 0.9091 \angle 0^\circ$$

$$H(j\omega_c) = \frac{10000}{11000 + j11000} = 0.6428 \angle -45^\circ$$

$$H(j0.1\omega_c) = \frac{10000}{11000 + j1100} = 0.9046 \angle -5.71^\circ$$

$$H(j10w_c) \frac{10000}{11000 + j110000} = 0.0905 \angle -84.29^\circ$$