



Electronic Clock - Multi-Function

黃元豪

Yuan-Hao Huang

國立清華大學電機工程學系

Department of Electrical Engineering

National Tsing-Hua University

Timer



- Timer is a counter with carry propagation.
 - Second : 0~59
 - Minute : 0~59
 - Hour : 0~23



Stopwatch

- Stopwatch
 - Start/Stop function
 - Lap/Reset button freezes the 7-segment LED display
 - When counting
 - Lap/Reset button resets the counter to zero.

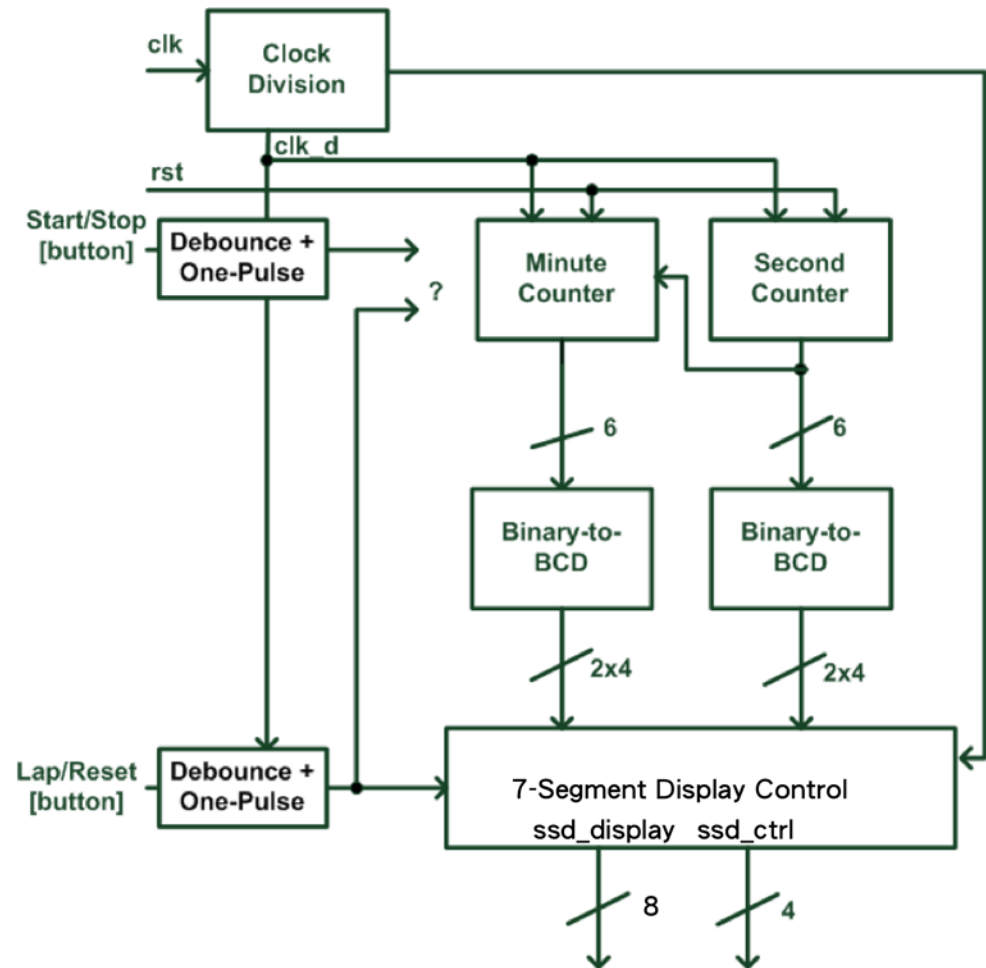

Timer



- Timer (Hour : Minute)
 - DIP switch is on
 - Press Button 1 to increase hour counter
 - Press Button 2 to increase minute counter
 - DIP switch is off
 - Press Button 1 for start/stop control
 - Press Button 2 for pause/resume control

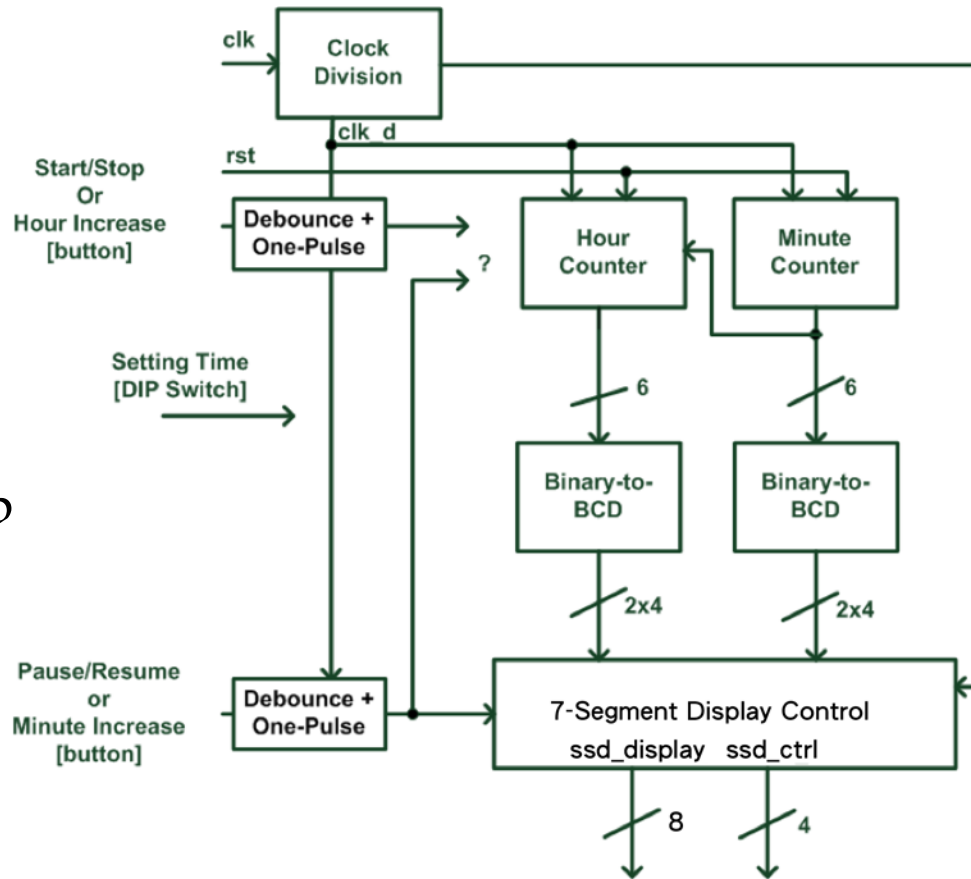

Stopwatch and Timer

