

# Data Structures

## CH4 Linked Lists

Prof. Ren-Shuo Liu

NTHU EE

Spring 2018

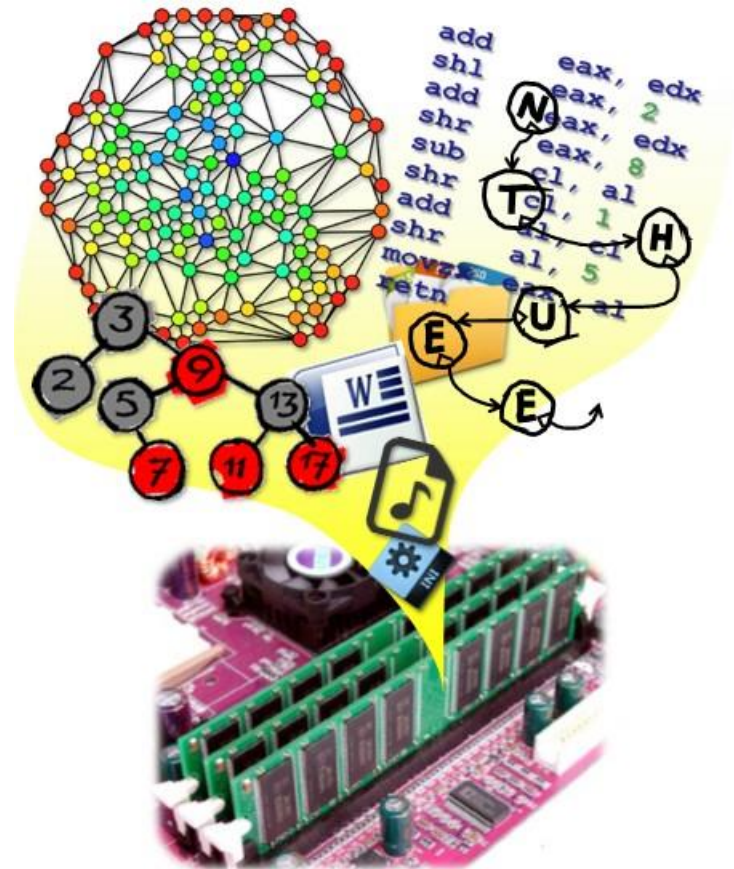

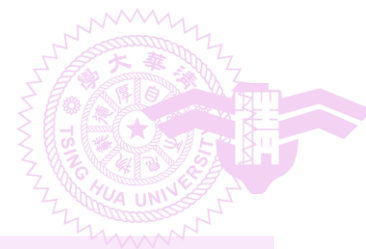

# Outline

---

- 4.1-4.3 Basic singly linked lists and chains
- 4.4-4.5 Circular lists
- 4.6-4.9 Linked stacks, queues, polynomials, and sparse matrices
- 4.10 Doubly linked lists
- 4.11 Generalized lists



# Sequential Representation of a List

- Insertion and deletion of arbitrary elements cause excessive data movement

list of three-letter words ending in AT

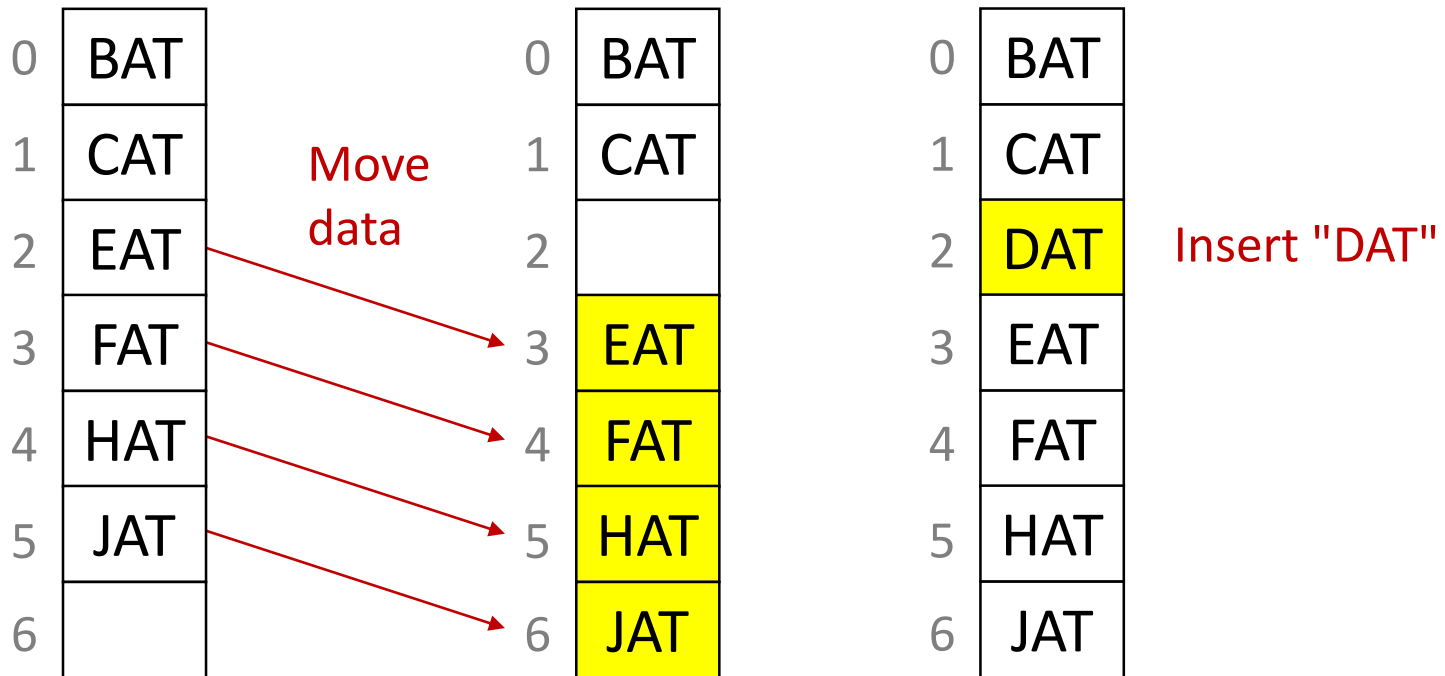

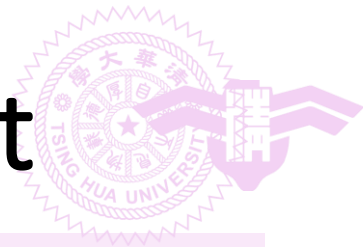

# Linked Representation of a List

- Insertion and deletion of arbitrary elements are simplified

Index denoting  
the next element

0	BAT	1
1	CAT	2
2	EAT	3
3	FAT	4
4	HAT	5
5	JAT	0
6		

0	BAT	1
1	CAT	2
2	EAT	3
3	FAT	4
4	HAT	5
5	JAT	0
6	DAT	

0	BAT	1
1	CAT	6
2	EAT	3
3	FAT	4
4	HAT	5
5	JAT	0
6	DAT	2

Adjust  
indices





# Singly Linked List (Chain)

- Insertion

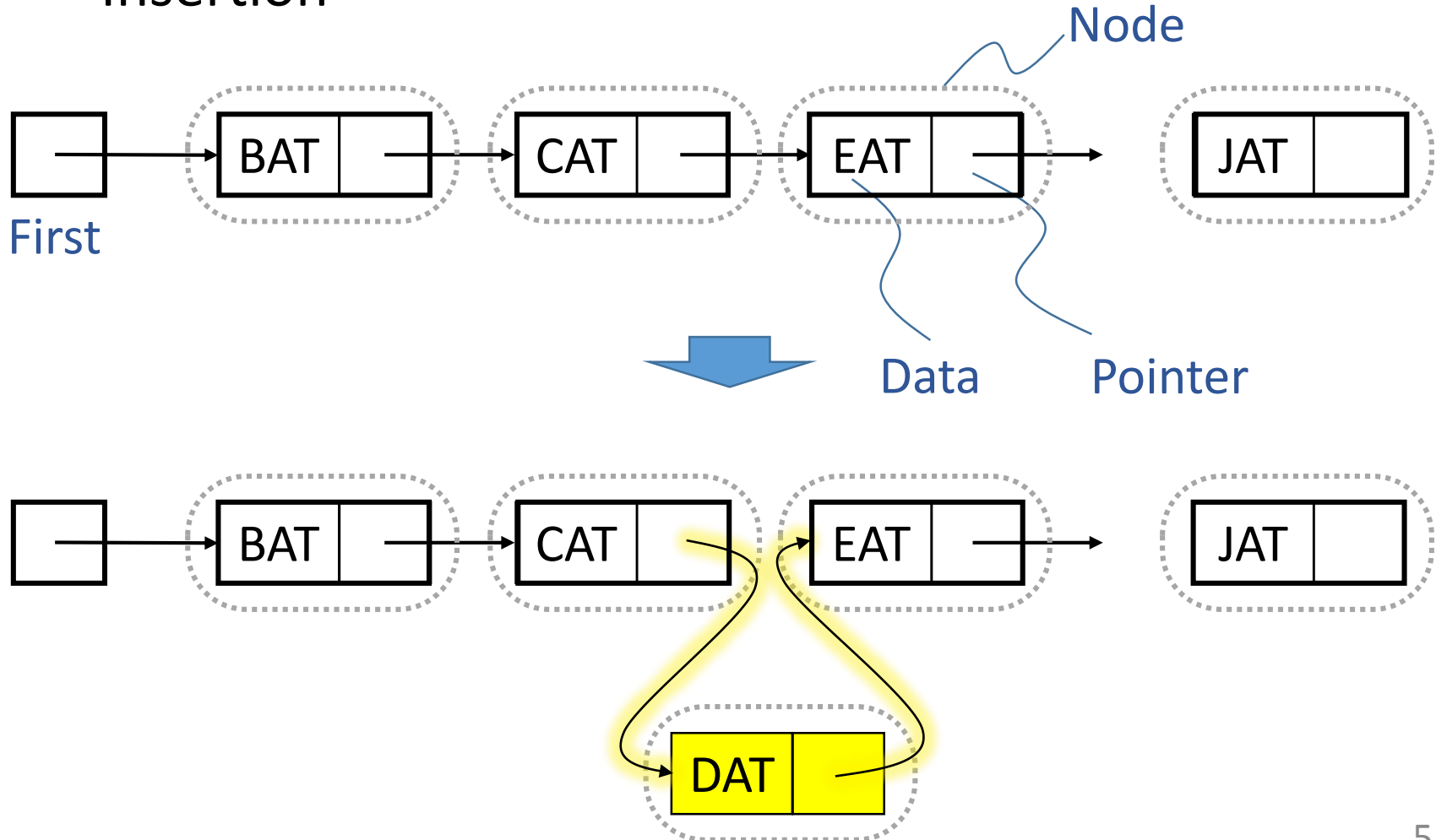



# Chain of Three-Letter Words (Composite Class Style)

```
class ThreeLetterNode;  
// forward declaration  
  
class ThreeLetterChain {  
public:  
    // chain manipulation operations  
    ...  
private:  
    ThreeLetterNode *first;  
};  
  
class ThreeLetterNode {  
friend class ThreeLetterChain;  
private:  
    char data[3];  
    ThreeLetterNode *link;  
};
```

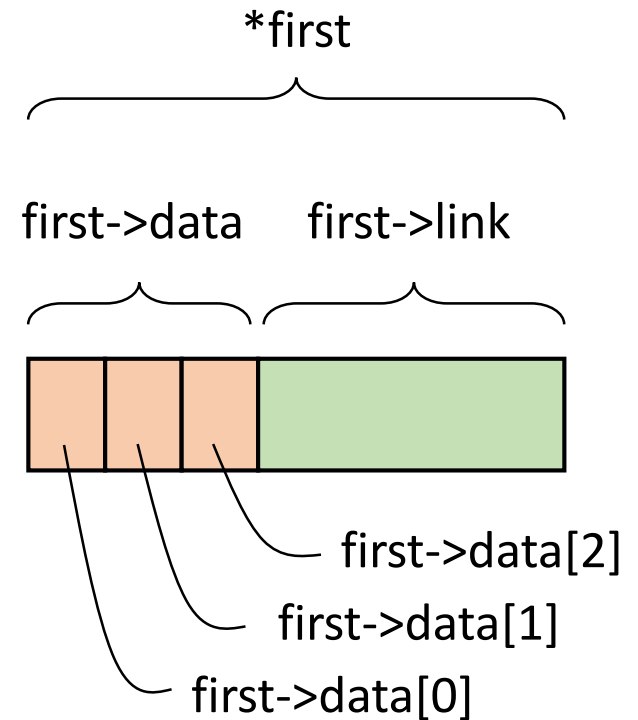



# Chain of Three-Letter Words (Nested Class Style)

```
class ThreeLetterChain {  
public:  
    // chain manipulation operations  
    ...  
private:  
    class ThreeLetterNode {  
public:  
    char data[3];  
    ThreeLetterNode *link;  
};  
    ThreeLetterNode *first;  
};
```

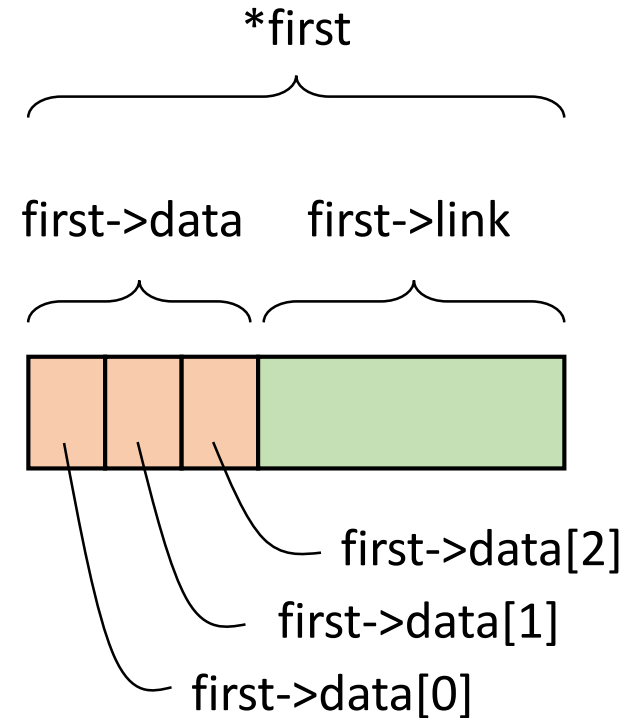

# Pointer Manipulation Example

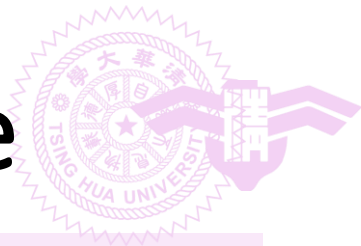

```
ThreeLetterNode * x;  
ThreeLetterNode * y;  
x = new ThreeLetterNode;  
y = new ThreeLetterNode;  
  
y->data[0] = 'B';  
y->data[1] = 'A';  
y->data[2] = 'T';  
y->link = x;  
  
*x = *y;  
  
x = y;  
  
x = y->link;  
delete x;  
delete y;
```

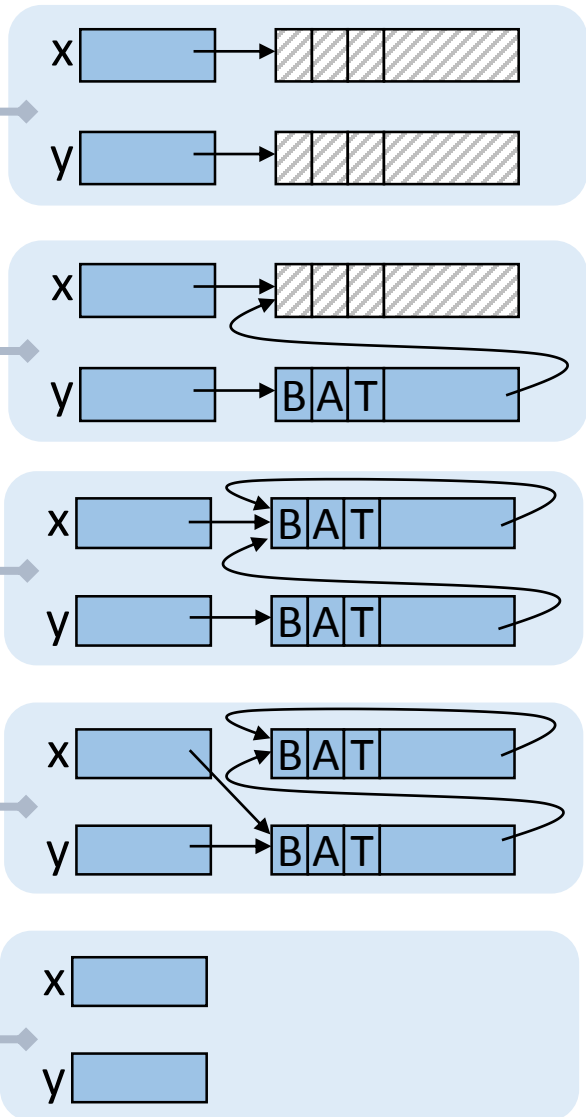

(For exempling purpose only)



# Chain of Integers in C++

```
class ChainNode; // forward declaration
class Chain
{
public:
    // chain manipulation operations
    ...
private:
    ChainNode *first;
}

class ChainNode {
friend class Chain;
public:
    ChainNode (int element = 0, ChainNode* next = 0)
        {data = element; link = next;}
private:
    int data;
    ChainNode *link;
};
```

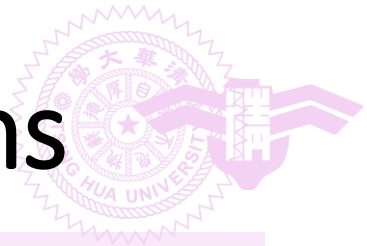

# Chain Manipulation Operations

- Example: create a chain with two nodes

```
void Chain::func1()  
{  
    // create and set fields of second node  
    ChainNode* second = new ChainNode(20, 0);  
  
    // create and set fields of first node  
    first = new ChainNode(10, second);  
}
```

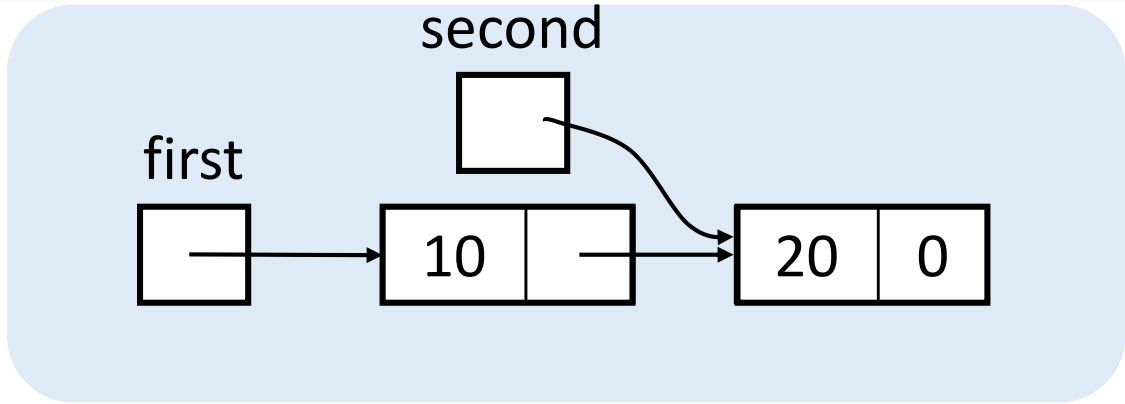

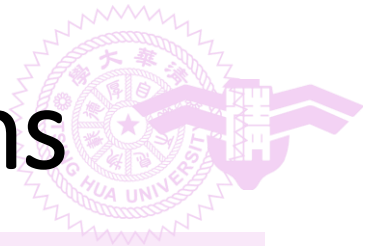

# Chain Manipulation Operations

- Insert a node with value 50

```
void Chain::func2(ChainNode* x)
{
    if(first == 0) // insert into an empty chain
        first = new ChainNode(50);
    else // x is the inserting point
        x->link = new ChainNode(50, x->link);
}
```

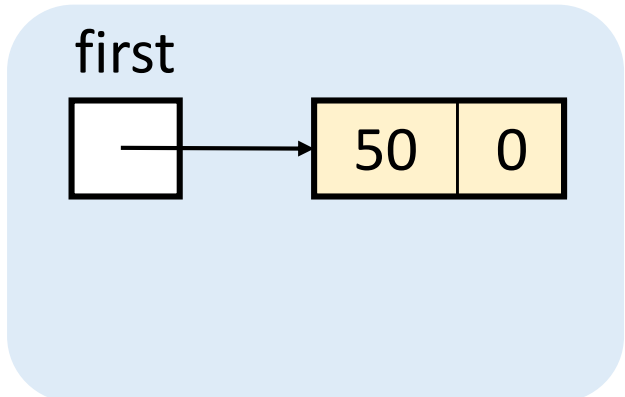

empty case

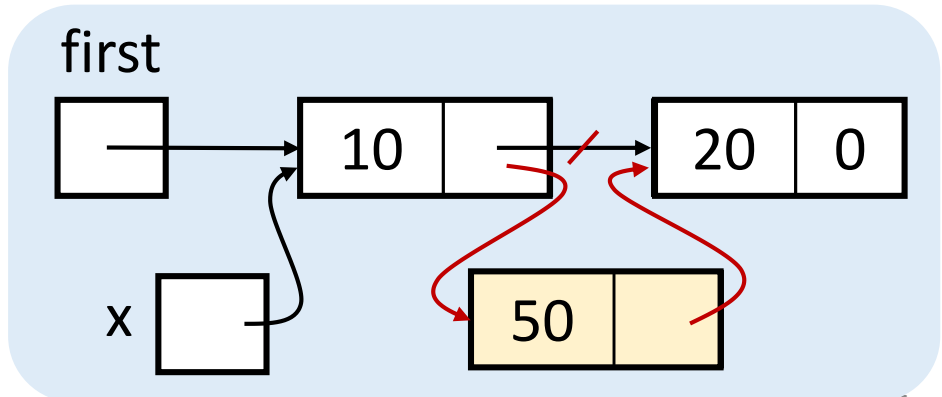

non-empty case

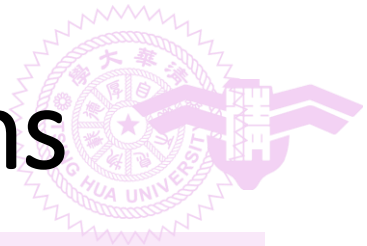

# Chain Manipulation Operations

- Delete/remove a node

```
void Chain::Delete(ChainNode* todel, ChainNode* prev)
{
    if(todel == first)
        first = first->link;
    else
        prev->link = todel->link;
    delete todel;
}
```

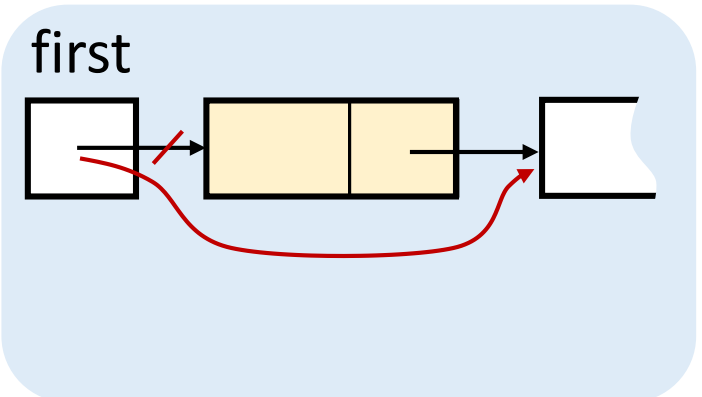

deleting first case

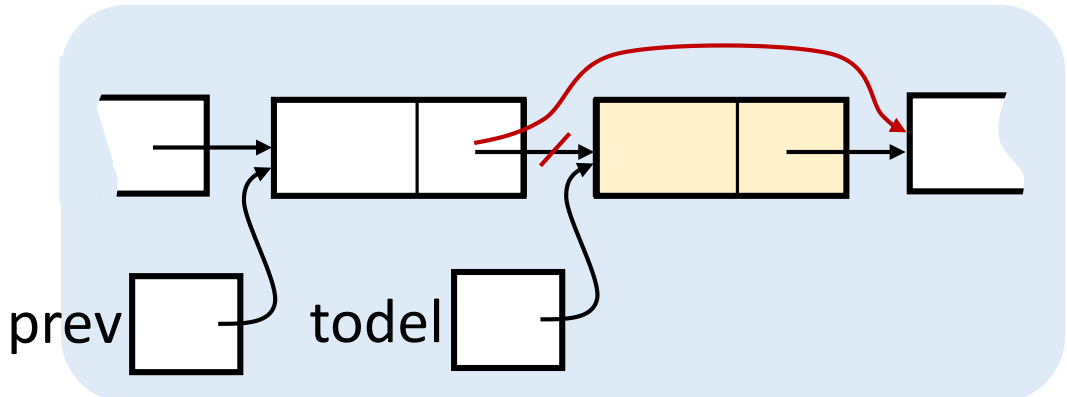

deleting others case





# Template Class Chain

---

- It is a waste of time for programmers to develop different types of chains and their associated algorithms over and over
  - Three-letter word chain
  - Integer chain
  - ...
- It is desirable for programmers to have a **reusable chain class**
  - **Template** and **iterators** can help



# Template Class Chain

```
template <class T> class ChainNode; // forward declaration
```

```
template <class T>
class Chain {
public:
    Chain( ) {first = 0;} // constructor
    // Chain manipulation operations
    .
    .
private:
    ChainNode<T>* first;
};
```

```
template <class T>
class ChainNode {
friend class Chain <T>;
private:
    T data;
    ChainNode<T>* link;
};
```

Usage:

```
Chain<int> i_list;
Chain<float> f_list;
Chain<Rectangle> r_list;
...
```



# Motivation of Chain Iterators

---

- Consider the following tasks for a container containing integers
  - Print out all integers
  - Find the **max, min, median, or mean** of all integers
  - Find the **sum, product, or sum of squares** of all integers
  - Find an integer that **maximizes a function**
- All these require us to **examine all elements** of the container



# Motivation of Chain Iterators

- Basic method to print out all elements

```
1  for each item in C  // C is a container
2  {
3      k = current item of C;
4      cout << k
5  }
```

- **First drawback of the naïve approach:**  
implementation is container-dependent

- For an array

```
1  for(int i = 0; i < n; i++)
3   k = a[i];
```

- For a list

```
1  for(ChainNode<int>* ptr = first; ptr != 0; ptr = ptr->link)
3   k = ptr->data;
```



# Motivation of Chain Iterators

---

- **Second drawback of the naïve approach** : operations need to be **member functions** as they access private data
  - However, not all operations are meaningful for all classes
    - e.g., sum is meaningful for Chain<int> but not for Chain<Rectangle>
  - Number of member functions can become large
  - Infeasible for the class designer to predict all the operations
  - Class users have to learn how the container class is implemented when they want to add member function



# C++ Iterators

---

- Object type that mimics pointers
- Typically, a nested class of a container class
- Designed to systematically access the elements of a container class one by one
- User can employ iterators to implement their own functions
- Design philosophy
  - Implementing iterators is tedious for designers
  - Users' jobs are simplified



# C++ Iterators

- Support **pointer-like operations**
  - Using operator overloading
- Iterators are classified into five categories according to the supported operations
  - All categories support **==**, **!=**, and **\*** (dereferencing)
  - **Input iterators**: support **read** access to the elements pointed at and **++**
  - **Output iterators**: support **write** access to the elements pointed at and **++**
  - **Forward iterators**: support **both input and output**
  - **Bidirectional iterators**: additionally support **--**
  - **Random access iterators**: additionally support jumps by **arbitrary** amounts

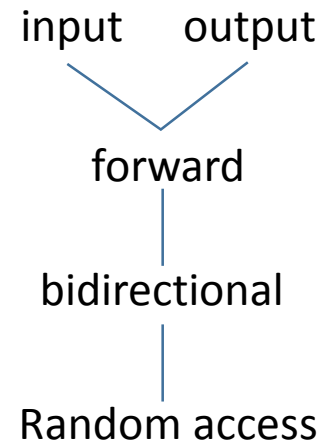



# Use of Iterators

- Print-out function for a chain of integers

```
for(Chain<int>::Iterator i = C.begin(); i!=C.end(); i++)  
{  
    k = *i;  
    cout << k;  
}
```

- Traverse chain nodes by **incrementing an iterator**
- Access chain nodes through **dereferencing**
- Users do not need to directly handle chain operations





# Combine Iterators with Template

- Generic print-out function for any container with iterators

```
template <class T> // T is an iterator type
void print(T begin, T end)
{
    while(begin != end) {
        cout << *begin;
        begin++;
    }
}
```

- Similar to STL sort() and find(), which are also generic functions
- Iterators enable us to **decouple the algorithms from containers**



# Chain Operations

---

- Design philosophy for choosing which operations to include in an object
  - Provide enough operations so that the class can be used in many applications
  - Not to include too many operations
    - Class becomes bulky and hard to understand
- Example for a chain object
  - **Inserting** at the back of a list
  - **Concatenating** two chains
  - **Reversing** a chain

# Inserting at the Back of a List



```
template <class T>
void Chain<T>::InsertBack(const T& e)
{
    if (first) { // nonempty chain
        let last points to the last node
        last->link = new ChainNode<T>(e);
    }
    else first = new ChainNode<T>(e);
}
```



# Concatenating Two Chains

```
template <class T>
void Chain <T>::Concatenate(Chain<T>& b)
{
    if (first) { // *this is nonempty
        let last point to the last node
        last->link = b.first;
    }else{
        first = b.first;
    }
    b.first = 0;
}
```



# Reversing a Chain

```
template <class T>
void Chain<T>::Reverse()
{
    ChainNode<T> *curr = first,
    ChainNode<T> *prev = 0;
    ChainNode<T> *r = 0;
    while (curr) {
        r = prev;           // r trails prev
        prev = curr;       // prev trails curr
        curr = curr->link; // curr moves to the next
        prev->link = r;     // link prev to r
    }
    first = prev;
}
```

} initializing

} advancing

} re-linking

} finalizing



# Illustrating Reversing a Chain

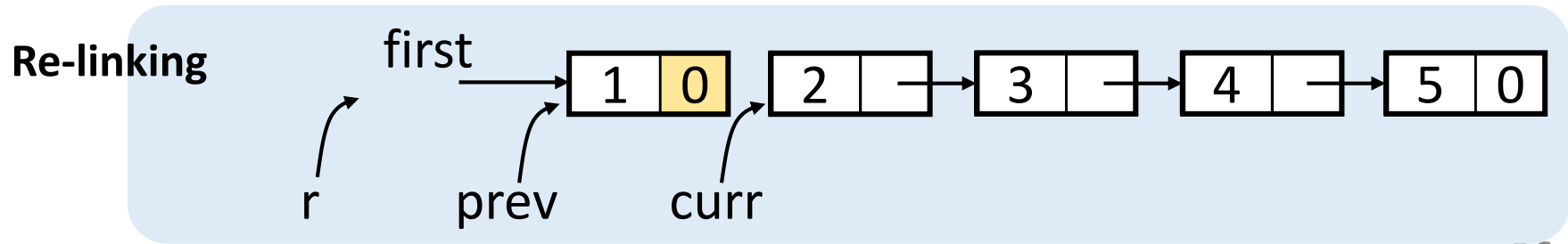
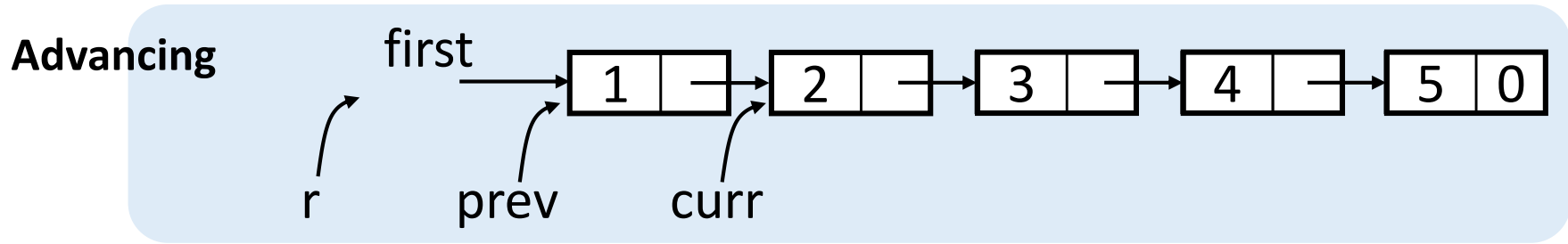
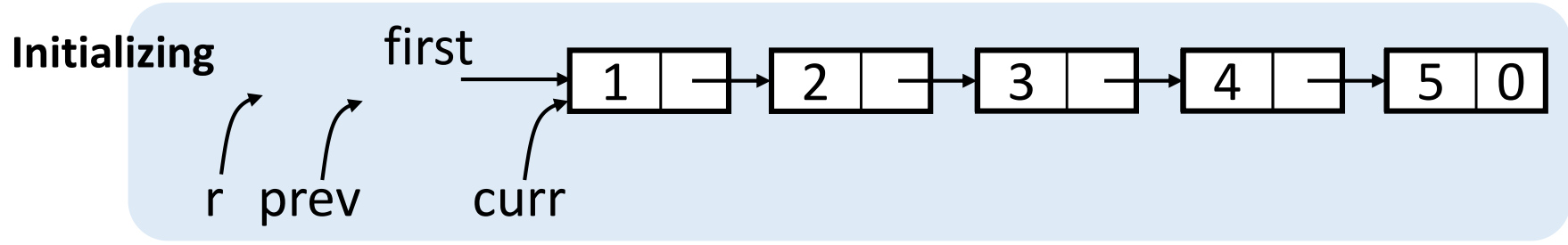



# Illustrating Reversing a Chain

Advancing

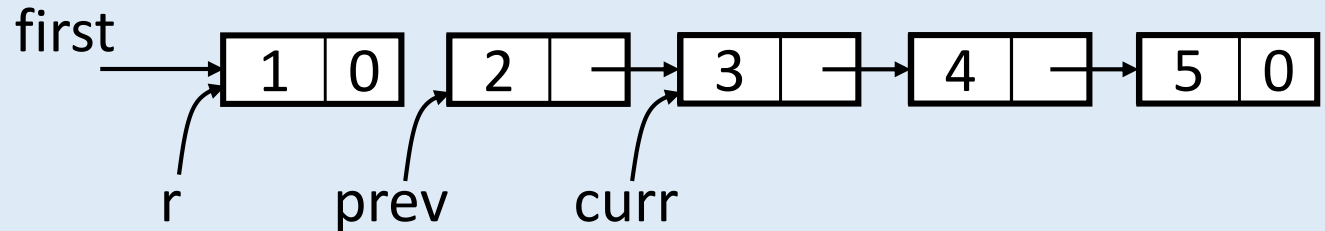

Re-linking

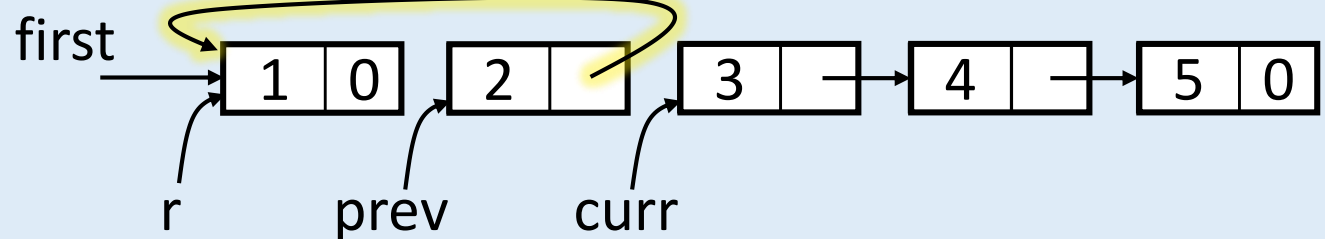

Advancing + re-linking

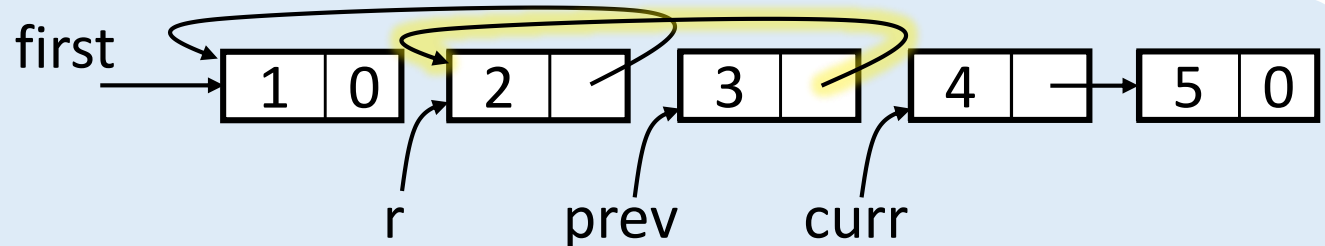



# Illustrating Reversing a Chain

Advancing + re-linking

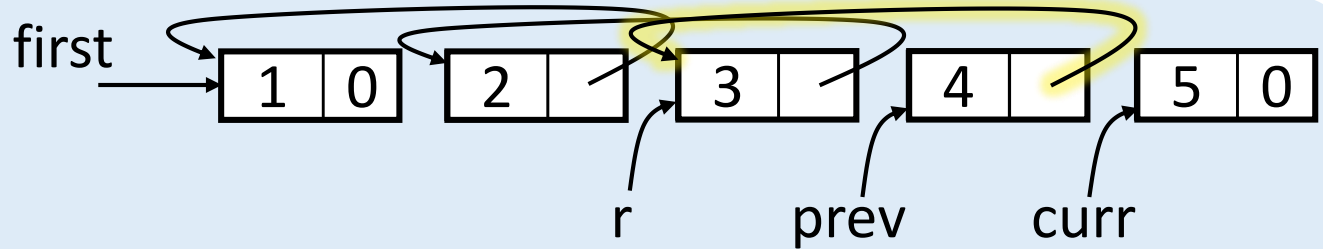

Advancing + re-linking

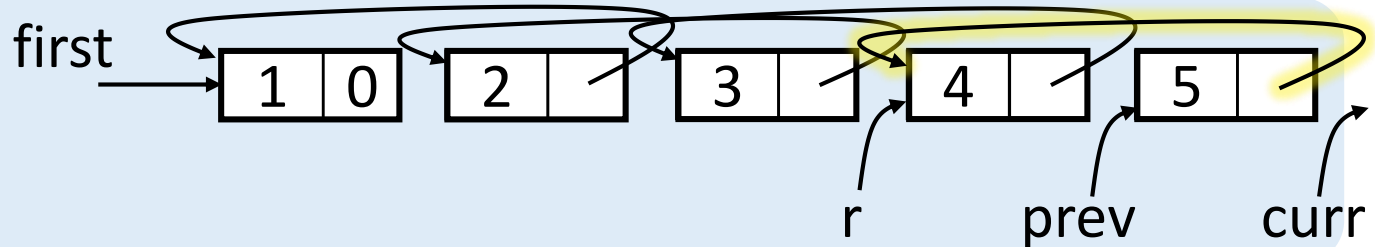

Finalizing

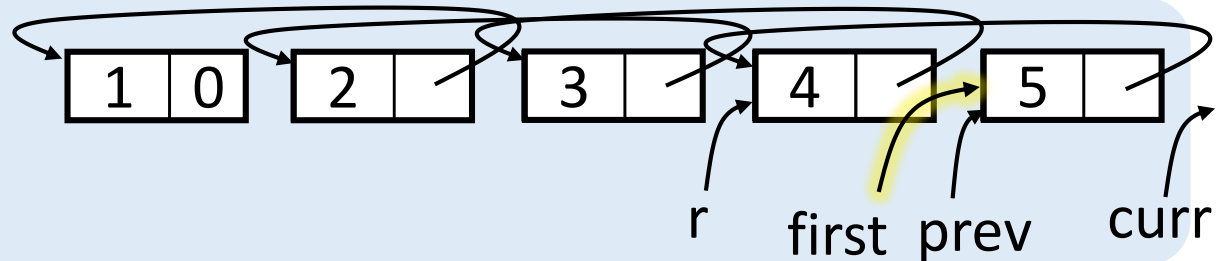





# Outline

---

- 4.1-4.3 Basic singly linked lists and chains
- **4.4-4.5 Circular lists**
- 4.6-4.7 Linked stacks, queues, polynomials, and sparse matrices
- 4.10 Doubly linked lists
- 4.11 Generalized lists

# Several Variants of Linked Lists

---



- Circular list
  - Access pointer pointing to the **first** node
  - Access pointer pointing to the **last** node
- Circular list with a **header** nodes
- Circular list with an **available** pool



# Circular Lists

- Link the last node with the first node

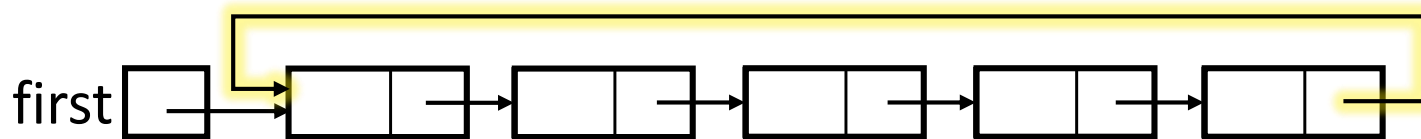

- Advantages
  - Capability of traversing a list with only a pointer pointing to a node in the list
  - Easy to rotate a list
- Potential disadvantages (can be solved)
  - Inserting a node becomes less efficient



# Insert at the Front

$\Theta(1)$  time

- If (`first == 0`) // empty list

first 0

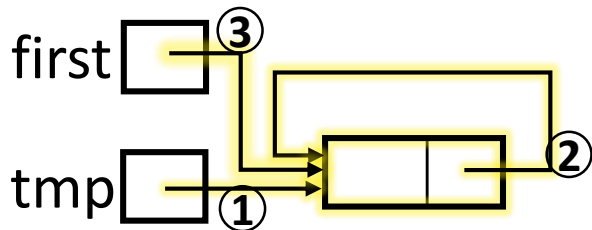

- ① `tmp = new node`
- ② `tmp->link = tmp`
- ③ `first = tmp`

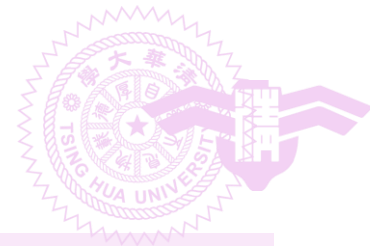

# Insert at the Front

$\Theta(n)$  time

- If (`first != 0`) // non-empty list

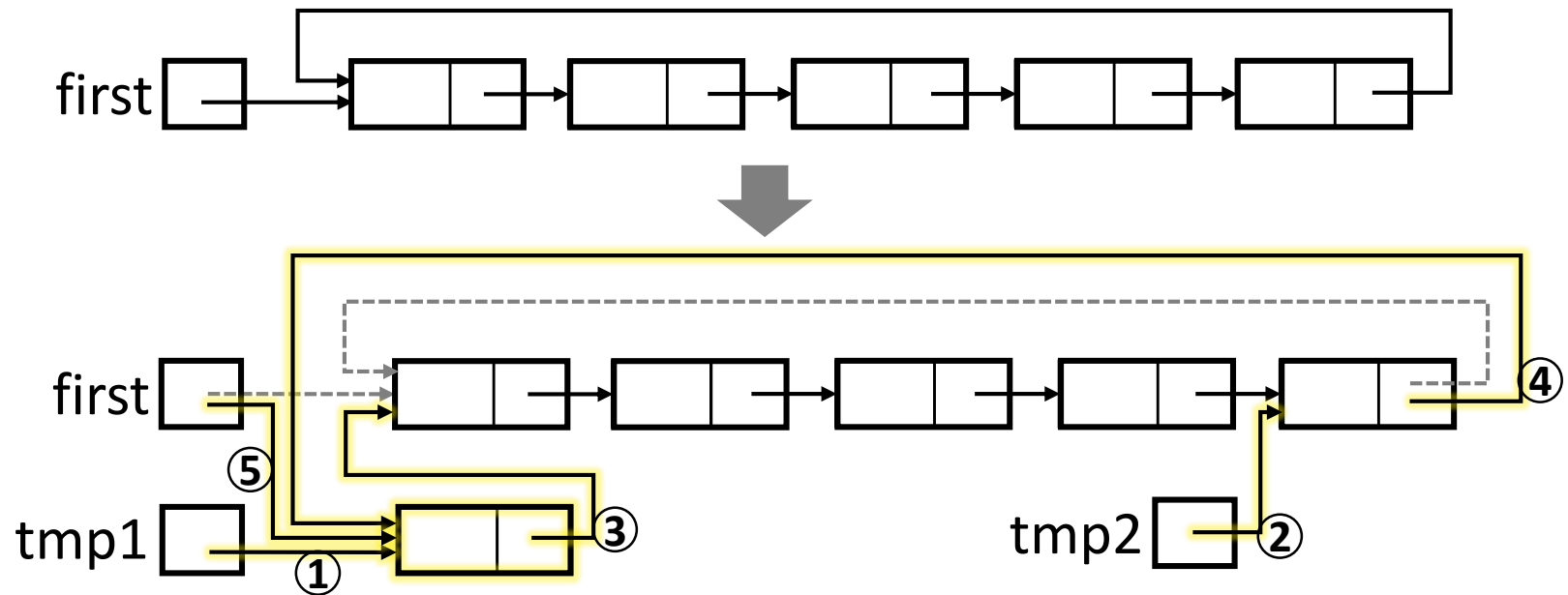

- ① `tmp1 = new node`
- ② traverse the whole list ( $\Theta(n)$ ) to let `tmp2` point to the last node.

- ③ `tmp1->link = first`
- ④ `tmp2->link = tmp1`
- ⑤ `first = tmp1`



# Quick Summary

---

- Drawback of circular lists with only an access pointer pointing to the **first** node
  - Inserting at the front becomes inefficient
    - Last node is involved
    - Time complexity is  $O(n)$
    - Worse than the original non-circular lists
- Solution
  - Let access pointer point to the last node
  - By doing so, inserting at the front consumes constant time



# Insert at the Front

$\Theta(1)$  time

- If (last == 0) // empty list

last [0]

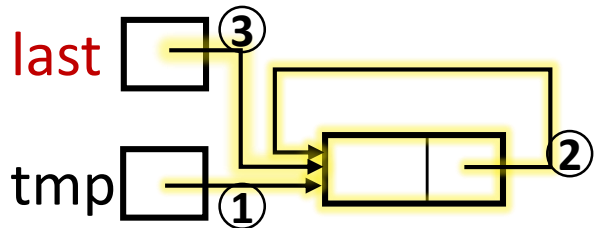

- ① tmp = new node
- ② tmp->link = tmp
- ③ last = tmp

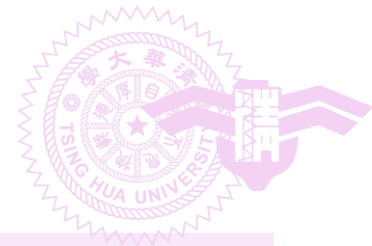

# Insert at the Front

- If( $last \neq 0$ )

$\Theta(1)$  time

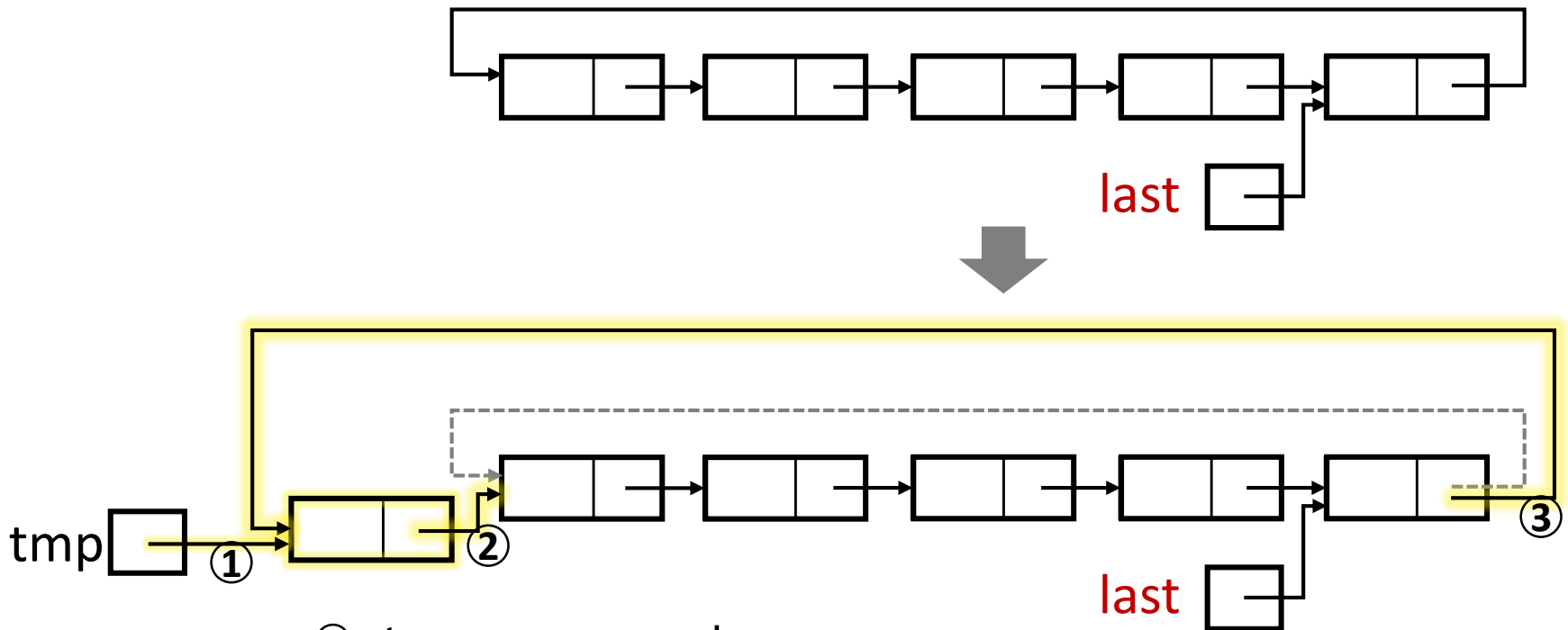

- ① `tmp = new node`
- ② `tmp->link = last->link`
- ③ `last->link = tmp`





# Lists with a Header Node

- Improve data structure regularity
- Avoid special case handling
  - No need to check whether the access pointer is zero
  - Same insertion procedure for both empty and non-empty lists
- Data field of the header node can be left unused or store information about the list (if appropriate)

Empty list

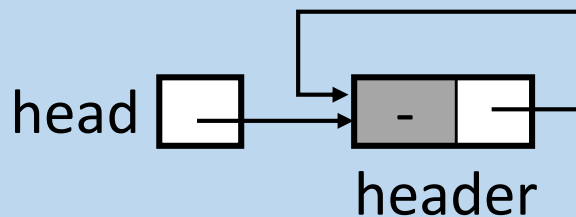

Non-empty list

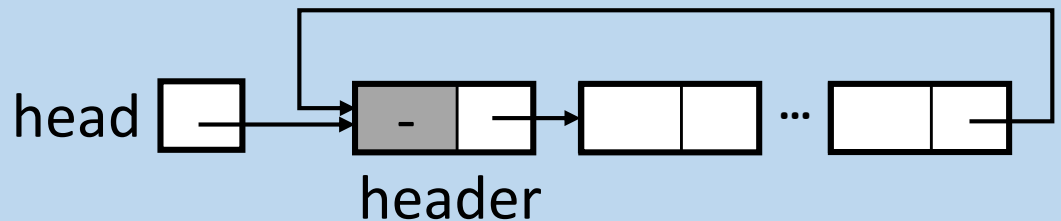



# Insert at the Front

$\Theta(1)$  time

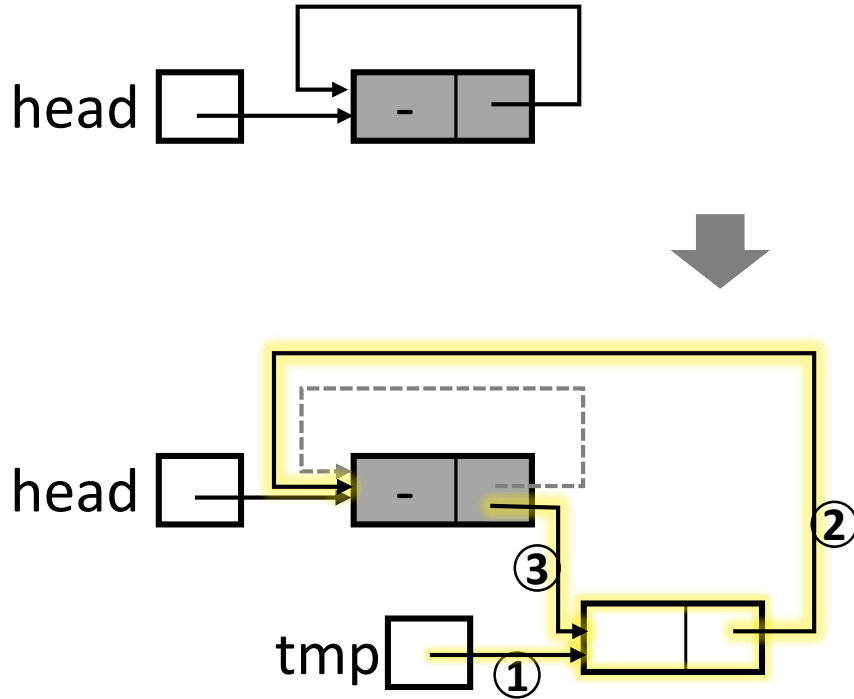

- ① tmp = new node
- ② tmp->link = head->link
- ③ head->link = tmp

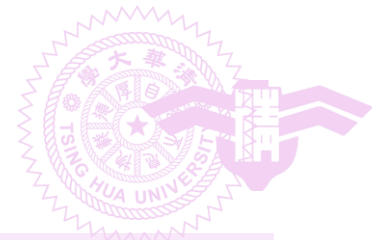

# Insert at the Front

$\Theta(1)$  time

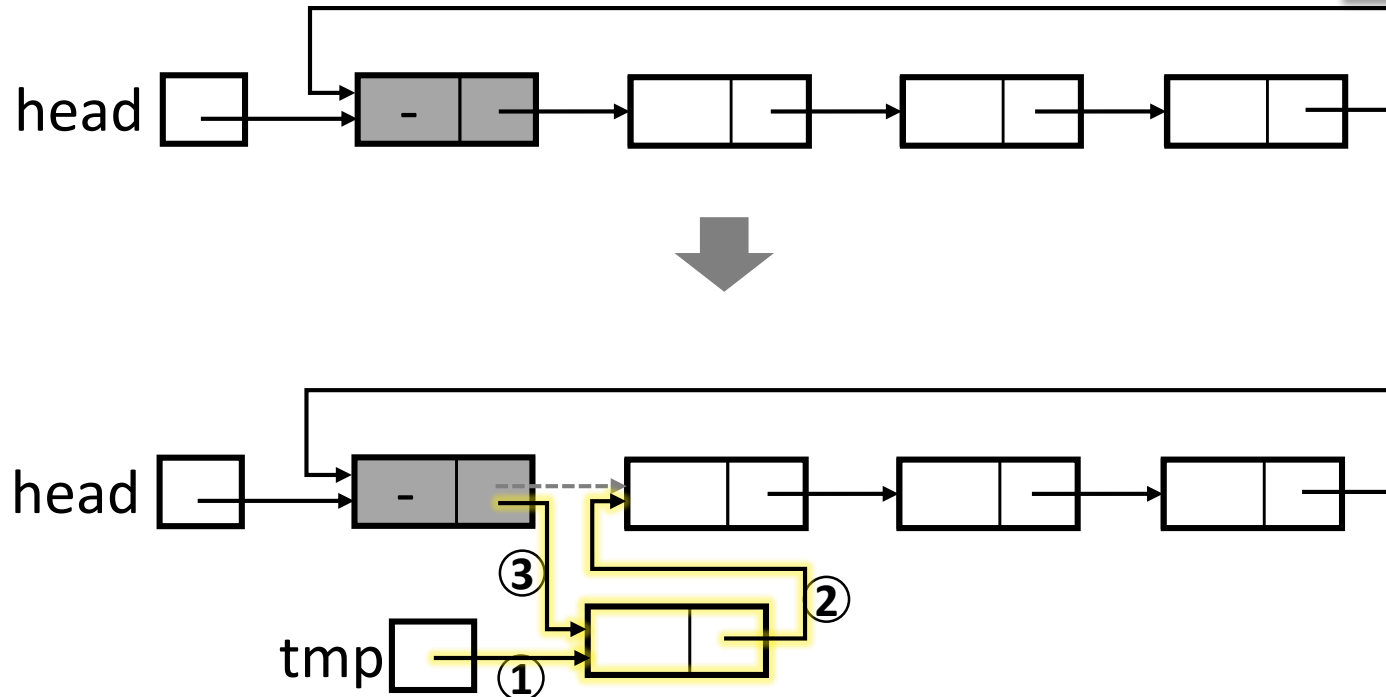

- ① `tmp = new node`
- ② `tmp->link = head->link`
- ③ `head->link = tmp`

# Lists with an Available Node Pool



- Use a pointer to hold pre-allocated and freed nodes
  - The pointer is shared by all the objects of the same class (i.e., the pointer is a **static** class member)
  - Expose `GetNode()` and `RetNode()` instead of **new** and **delete** (or one can overload **new** and **delete**)
  - Original **new** and **delete** are used only when necessary
- Benefits
  - Reduces frequent **new** and **delete**, which are costly operations
  - Chain can be deleted in  $O(1)$  time
    - Deleting an original chain is of  $O(n)$  time



# Available Space Lists

List1

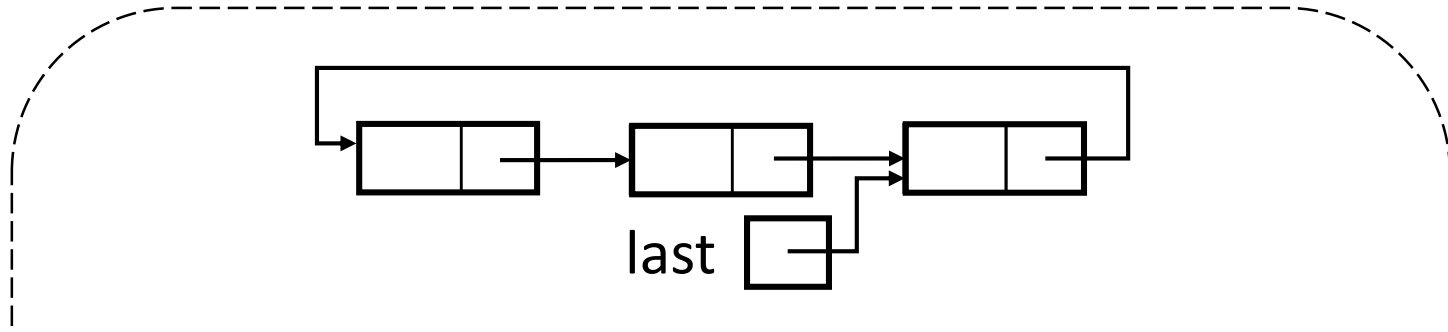

av



List2

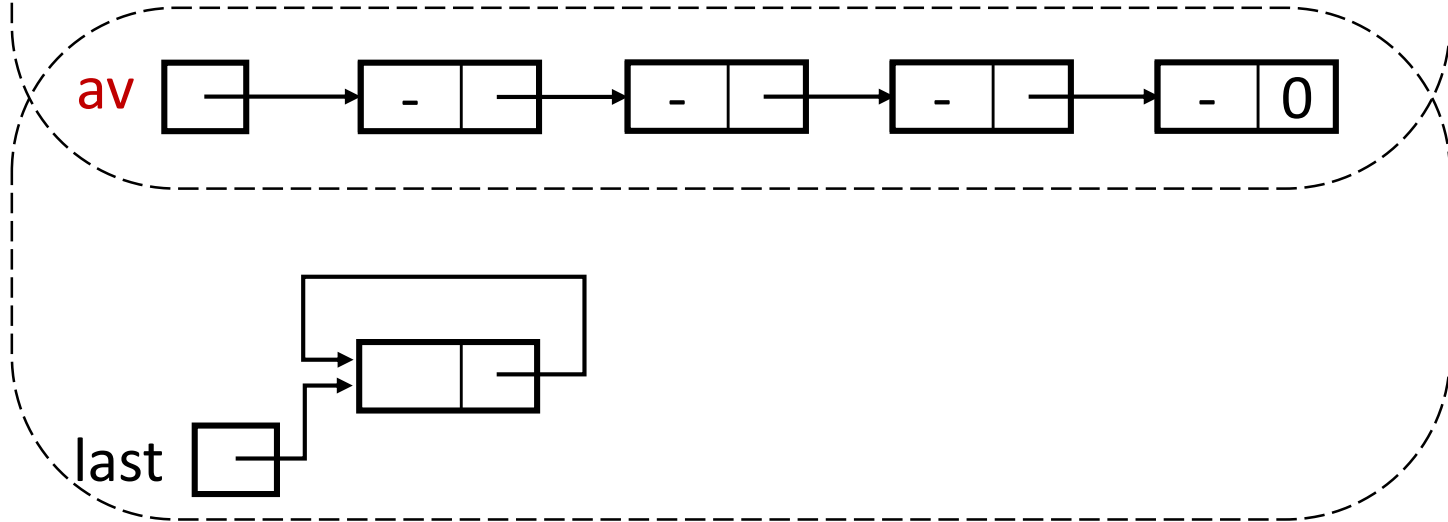

List3, List4 ...



# Available Space Lists

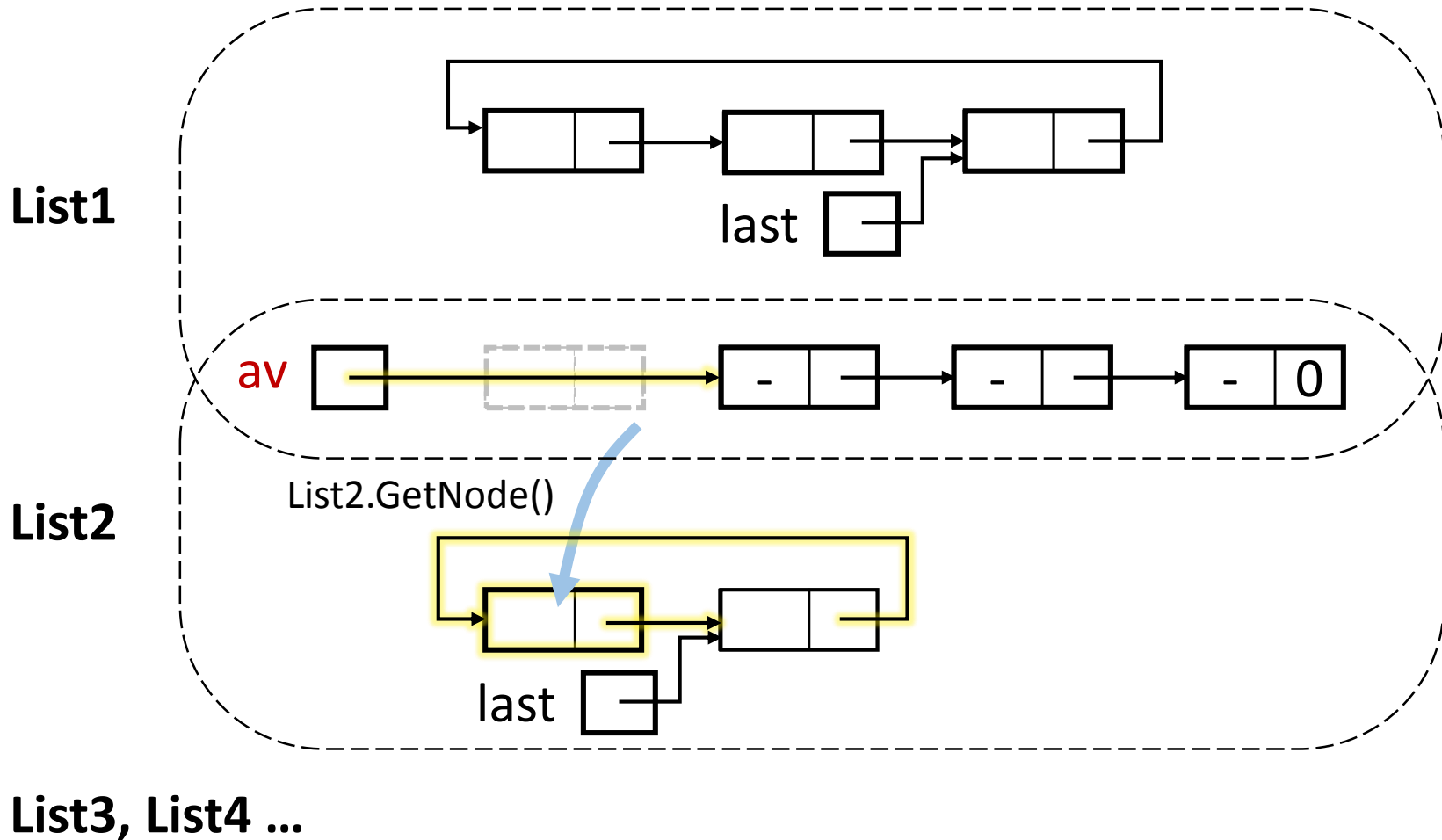



# Available Space Lists

List1

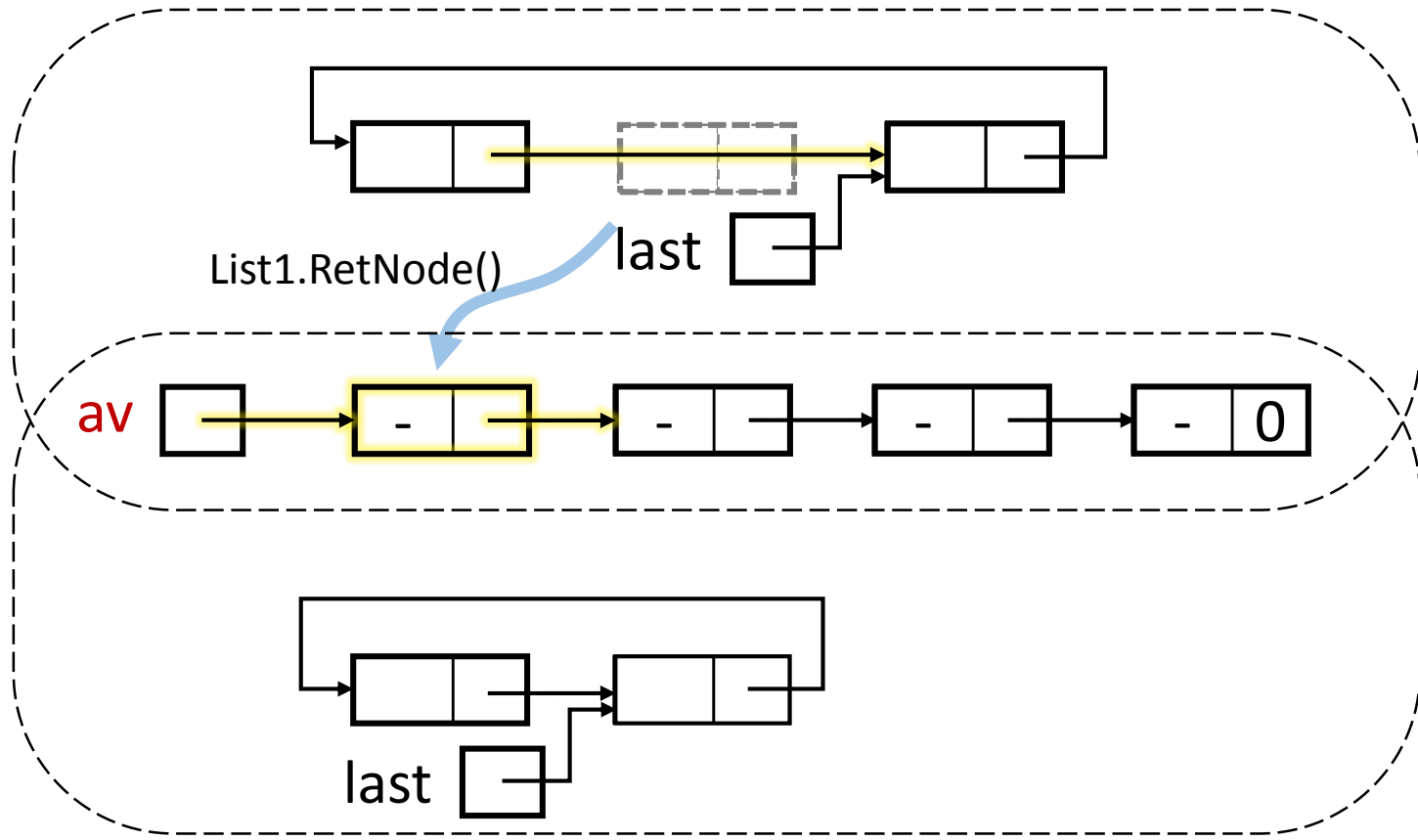

List2

List3, List4 ...



# Getting a Node

```
template <class T>
ChainNode<T>* CircularList<T>::GetNode()
{ // Provide a node for use
  ChainNode<T>* x;
  if (av){
    x = av;
    av = av->link;
  }else{ // out of available nodes
    x = new ChainNode<T>;
  }
  return x;
}
```

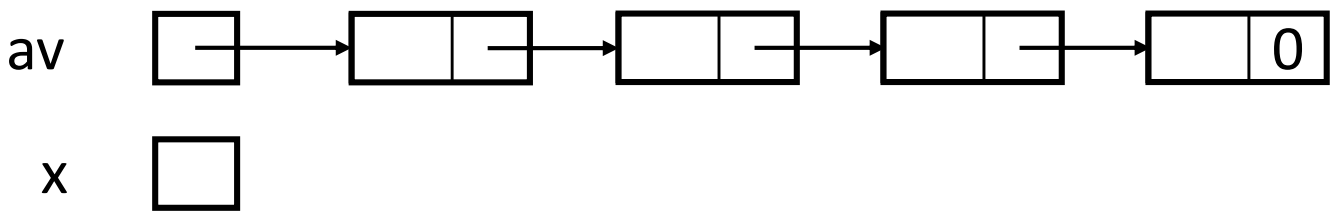





# Returning a Node

```
template <class T>  
void CircularList<T>::RetNode(ChainNode<T>*& x)  
{// Free the node pointed to by x  
  x->link = av;  
  av = x;  
  x = 0;  
}
```

reference to a pointer

x is cleared after being returned. This could prevent a freed node from still being used.

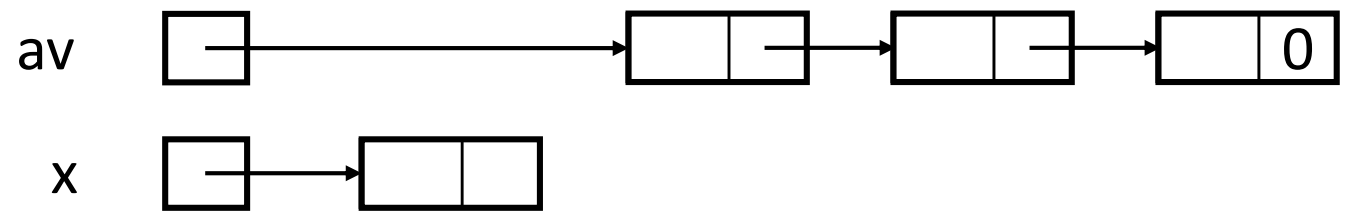

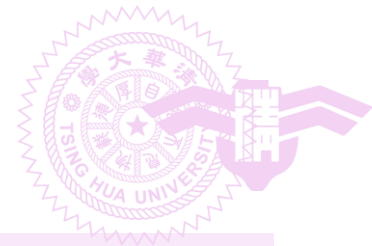

# Clearing a List

```
template <class T>
void CircularList<T>::~~CircularList()
{ // Delete/clear the circular list
  if(last) {
    ChainNode<T>* x = last->link;
    last->link = av; // last node linked to av
    av = x;
    // first node of list becomes front of av list
    last = 0;
  }
}
```

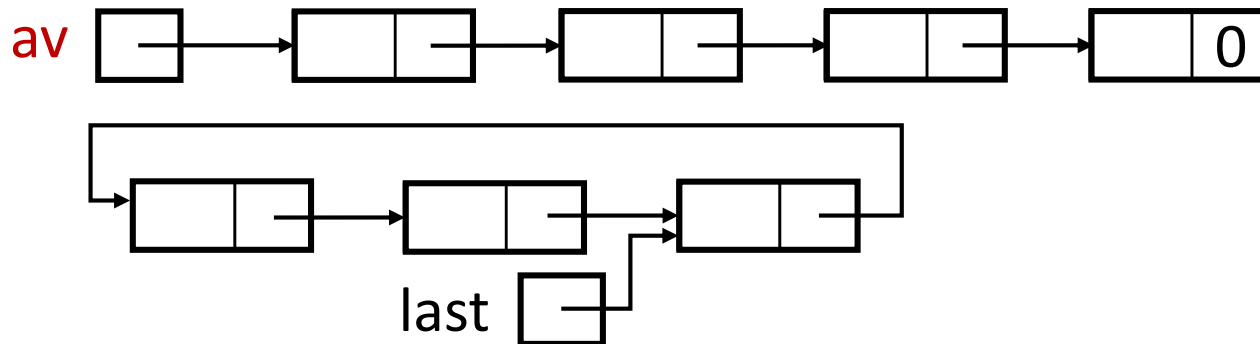



# Quick Summary

---

- Different list implementations have their pros and cons
  - No one-size-fit-all solution
  - No best solution
- Even the vanilla (singly, non-circular) list implementation has its suitable use
  - E.g., managing the available nodes of the available-space lists
  - Usage scenarios in which a list is usually get inserted and deleted at the front and seldom traversed

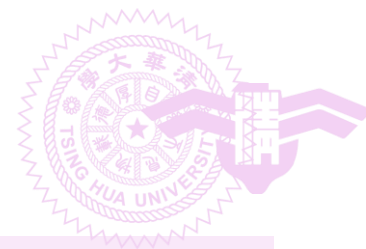

# Outline

---

- 4.1-4.3 Basic singly linked lists and chains
- 4.4-4.5 Circular lists
- **4.6-4.9 Linked stacks, queues, polynomials, equivalence classes, and sparse matrices**
- 4.10 Doubly linked lists
- 4.11 Generalized lists



# Linked Stacks and Queues

- Stack

- Last in first out

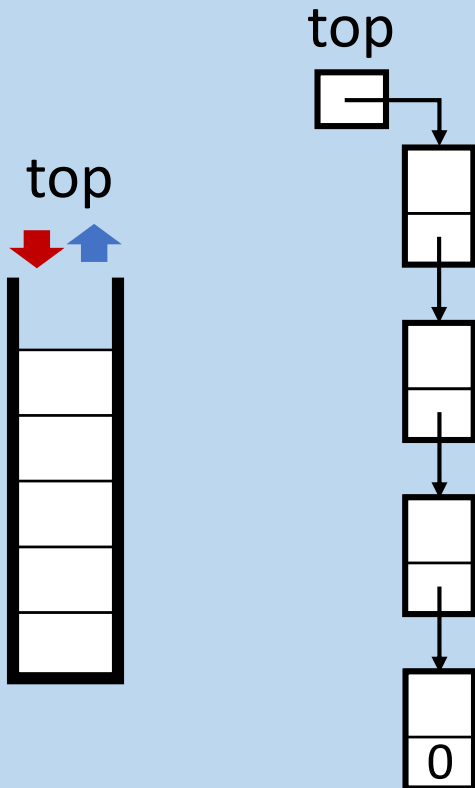

- Queue

- First in first out

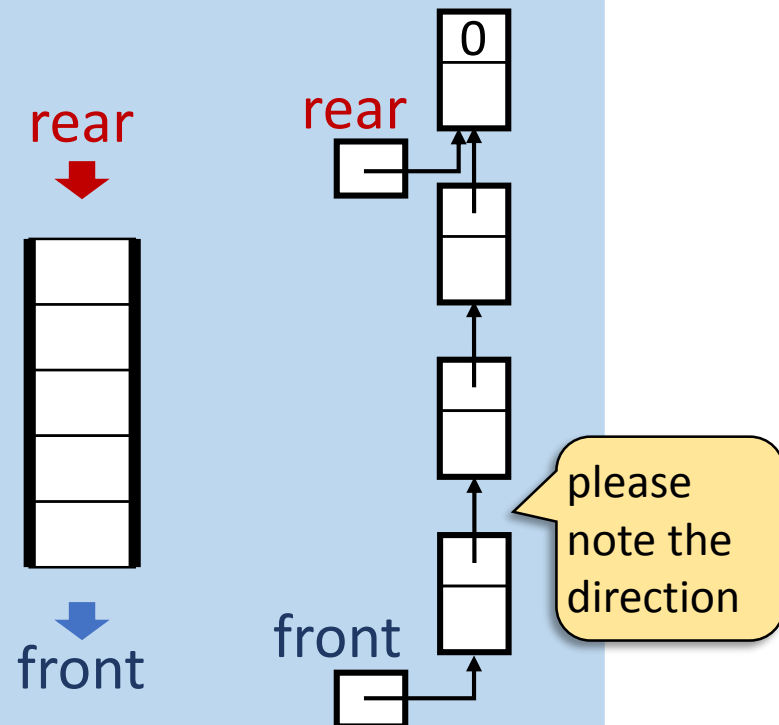

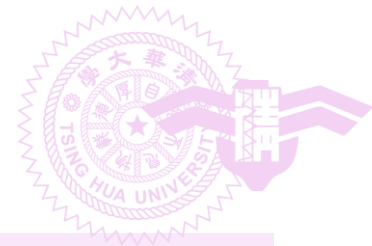

# Linked Stack Operations

```
template <class T>
void LinkedStack <T>::Push(const T& e) {
    top = new ChainNode <T>(e, top);
}
```

```
template <class T>
void LinkStack <T>::Pop( )
{ // Delete top node from the stack
    if (IsEmpty()) throw "Stack is empty. Cannot delete.";
    ChainNode <T> *delNode = top;
    top = top->link; // remove top node
    delete delNode; // free the node
}
```

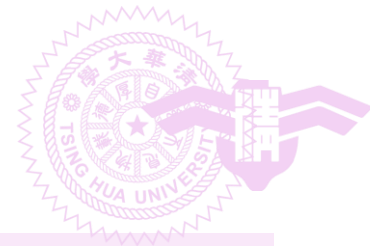

# Linked Queue Operations

```
template <class T>
void LinkedQueue <T>::Push(const T& e)
{
    if (IsEmpty( )) front = rear = new ChainNode(e,0);
    else rear = rear->link = new ChainNode(e,0);
    //attach node and update rear
}
```

```
template <class T>
void LinkedQueue <T>::Pop()
{ // Delete first element in queue
    if (IsEmpty()) throw "Queue is empty. Cannot delete.";
    ChainNode<T> *delNode = front;
    front = front->link; // remove first node from chain
    delete delNode;
}
```



# Linked Polynomials

---

- We can have Polynomials that IS-IMPLEMENTED-IN-TERMS-OF Lists (instead of arrays)
- Definition
  - A data object of Type A **IS-IMPLEMENTED-IN-TERMS-OF** a data object of Type B if the Type B object is central to the implementation of the Type A object
  - This relationship is usually expressed by declaring the Type B object as a data member of the Type A object





# Polynomial Classes

```
struct Term {  
    int coef;  
    int exp;  
    Term Set(int c, int e)  
    { coef=c; exp=e; return *this; }  
};  
class Polynomial{  
public:  
    // Polynomial operations  
private:  
    Chain<Term> poly;  
}
```

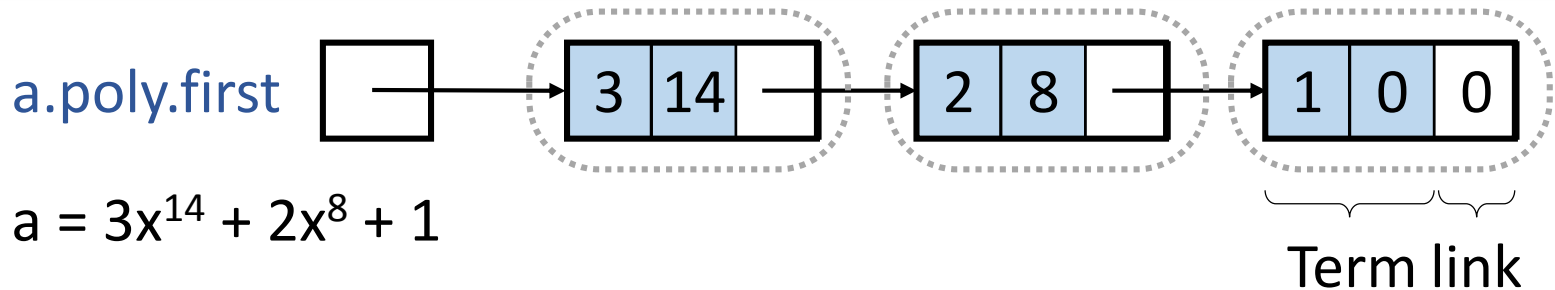



# Adding Polynomials

$$\begin{array}{r}
 3x^{14} + \phantom{0x^{10}} + \phantom{0x^8} + \phantom{0x^6} + 1 \\
 + 8x^{14} + -3x^{10} + \phantom{0x^8} + 10x^6 \\
 \hline
 11x^{14} + -3x^{10} + 2x^8 + 10x^6 + 1
 \end{array}$$

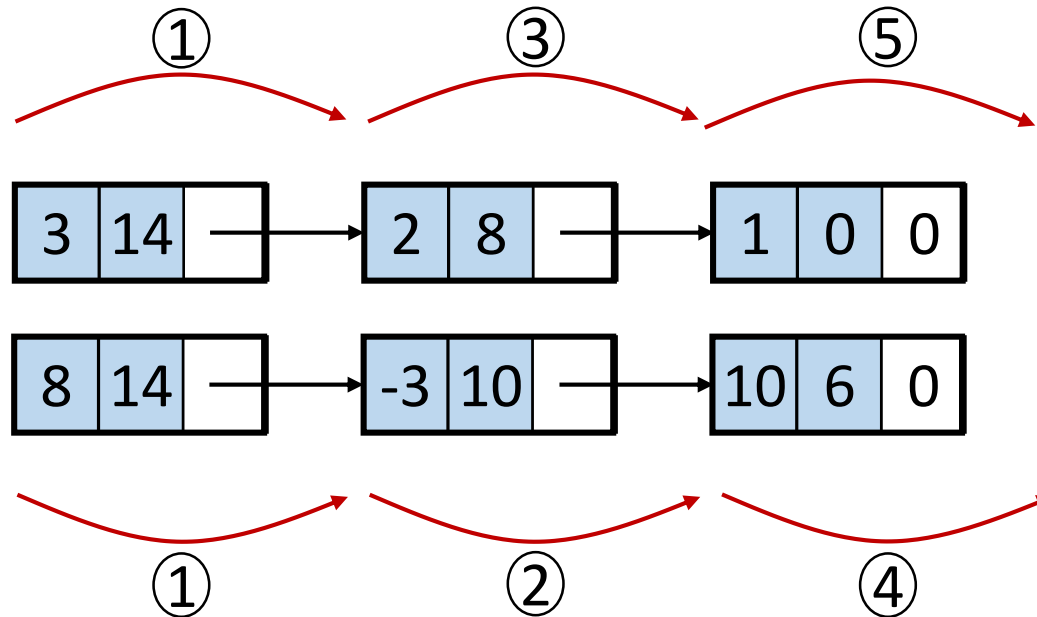

```

Polynomial Polynomial::operator+(const Polynomial& b) const
{
    Term temp;
    Chain <Term>::ChainIterator ai = poly.begin(), bi = b.poly.begin();
    Polynomial c;
    while (ai && bi) {
        if (ai->exp == bi->exp) {
            int sum = ai->coef + bi->coef;
            if (sum) c.poly.InsetBack (temp.Set(sum, ai->exp));
            ai++; bi++;
        } else if (ai->exp < bi->exp) {
            c.poly.InsertBack(temp.Set(bi->coef, bi->exp)) ;
            bi++;
        } else {
            c.poly.InsertBack(temp.Set(ai->coef , ai->exp)) ;
            i++;
        }
    }
    while (ai) {
        c.poly.InsertBack(temp.Set(ai->coef,ai->exp));      ai++;
    }
    while (bi) {
        c.poly.InsertBack (temp.Set(bi->coef,bi->exp));      bi++;
    }
    return c;
}

```



# Outline

---

- 4.1-4.3 Basic singly linked lists and chains
- 4.4-4.5 Circular lists
- 4.6-4.9 Linked stacks, queues, polynomials, **equivalence classes, and sparse matrices**
- 4.10 Doubly linked lists
- 4.11 Generalized lists

# Equivalence Class Problem

- Integrated circuit (IC) fabrication involves exposing a silicon wafer using a series of masks (光罩)
- Each mask consists of several polygons that define metal lines
- Connected lines form power/signal net

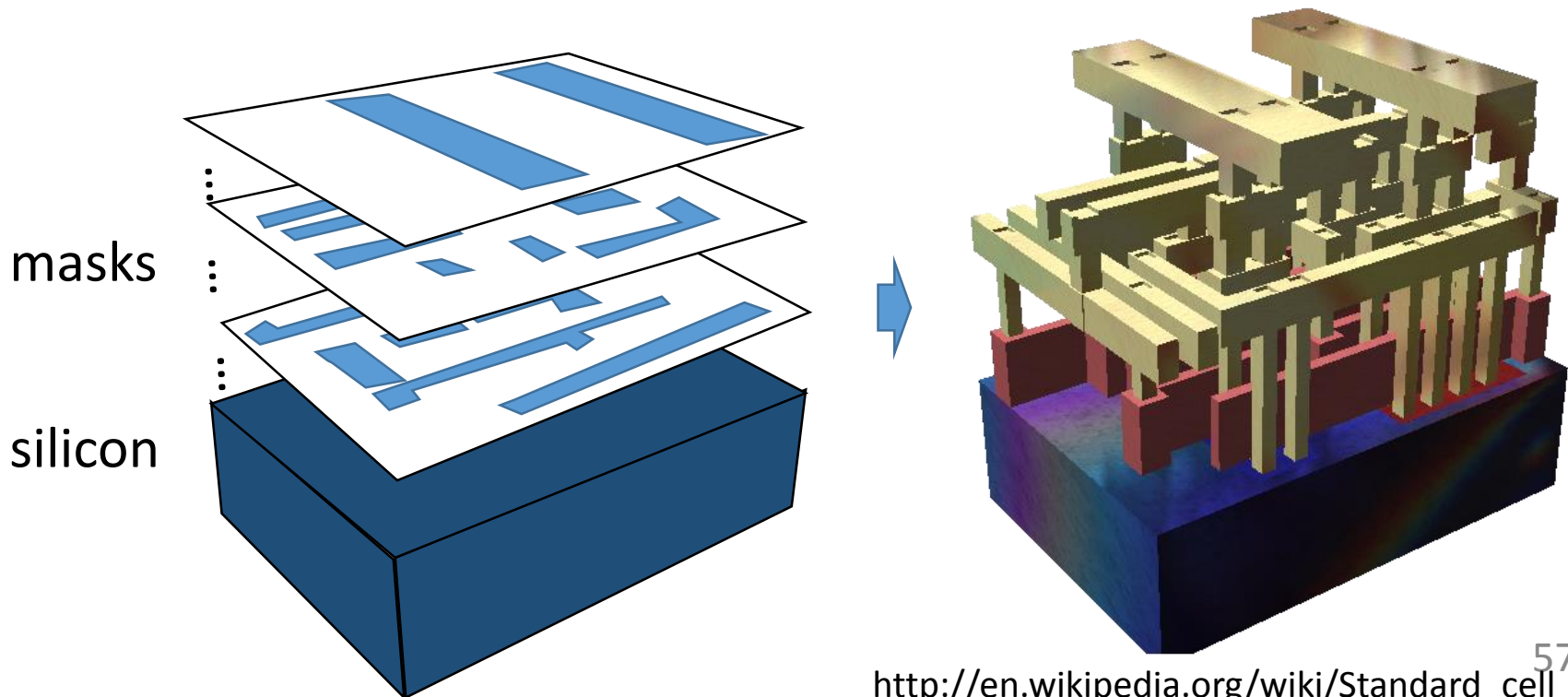

# Basic IC Fabrication Procedure

(Supplementary information)

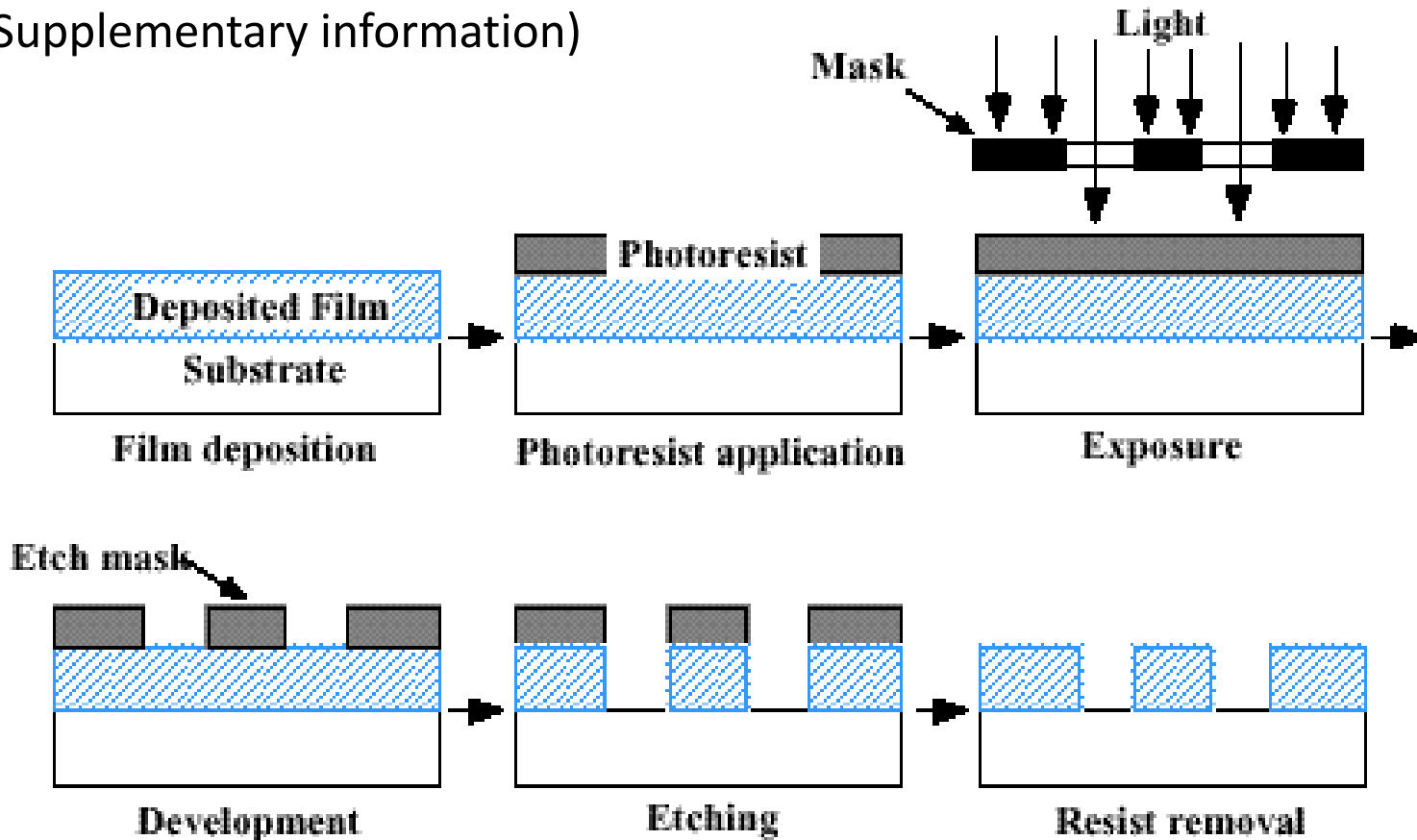

The Fabrication of Integrated Circuits

<https://www.youtube.com/watch?v=35jWSQXku74>

<http://www.hitequest.com/Kiss/VLSI.htm>

# Gallery

(Supplementary information)

Highly magnified view of copper tracks (insulating layers have been removed)

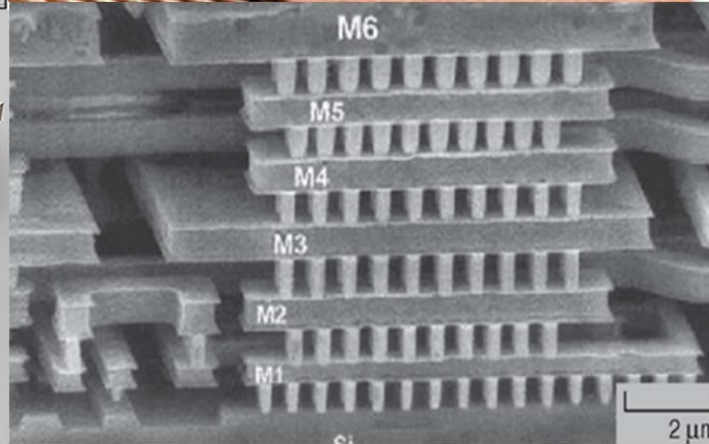
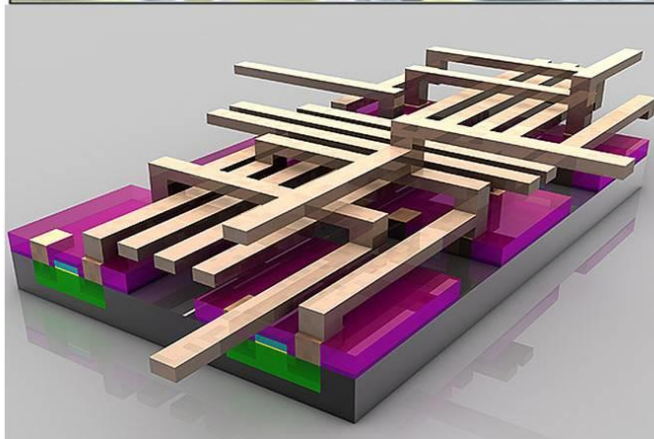
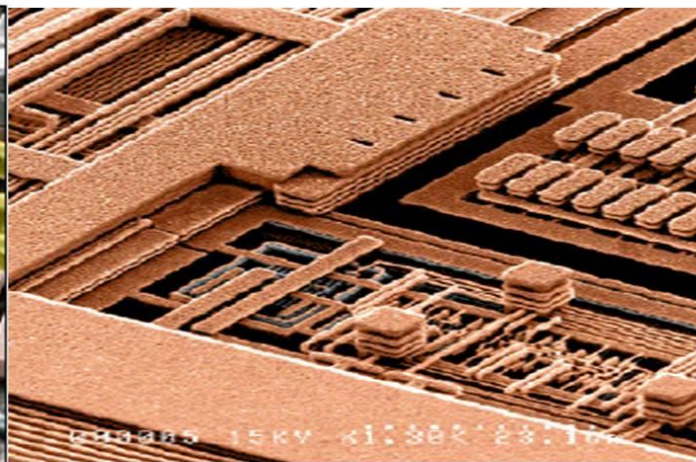
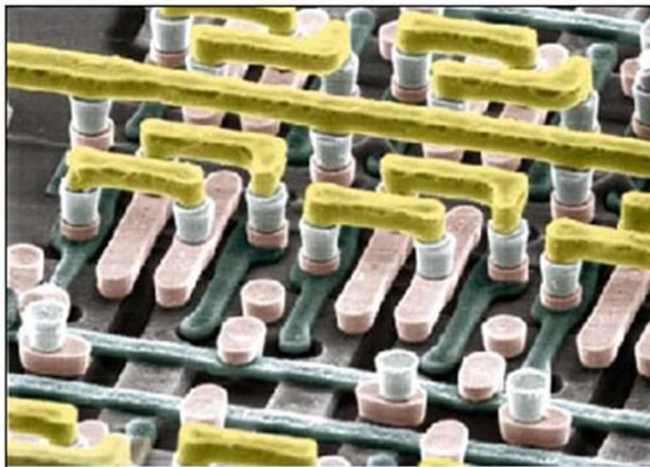

state of the art has a 0.02 μm line pitch

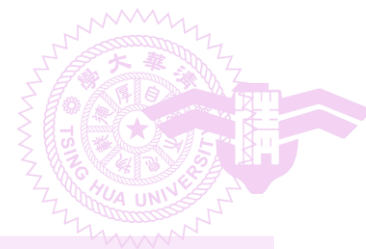

# Equivalence Class Problem

---

- We are given **polygons** and **overlap/equivalence pairs** (denoted by ' $\equiv$ ') among polygons
- We want to partition the polygons into equivalence classes
- For example
  - Input:  $0 \equiv 4$ ,  $3 \equiv 1$ ,  $6 \equiv 10$ ,  $8 \equiv 9$ ,  $7 \equiv 4$ ,  $6 \equiv 8$ ,  $3 \equiv 5$ ,  $2 \equiv 11$ , and  $11 \equiv 0$
  - Output:  $\{0, 2, 4, 7, 11\}$ ;  $\{1, 3, 5\}$ ;  $\{6, 8, 9, 10\}$





# Properties

---

- ' $\equiv$ ' is reflexive
  - For any polygon  $x$ ,  $x \equiv x$
- ' $\equiv$ ' is symmetric
  - For any two polygons  $x$  and  $y$ , if  $x \equiv y$ , then  $y \equiv x$
- ' $\equiv$ ' is transitive
  - For any three polygons  $x$ ,  $y$ , and  $z$ , if  $x \equiv y$  and  $y \equiv z$ , then  $x \equiv z$



# Algorithm

---

- Phase 1
  - Read and **store all equivalence pairs**  $(i, j)$
- Phase 2
  - Begin at polygon 0 and find all pairs of the form  $(0, j)$ 
    - 0 and these  $j$ 's are of the same class
  - Find all pairs of the form  $(j, k)$ 
    - By transitivity,  $k$  is in the same class as 0 and  $j$
  - Continue in this way until the entire equivalence class containing 0 has been found and output
  - Find an **object not yet output**, which is in a new equivalence class
  - Find and output the new equivalence class as before

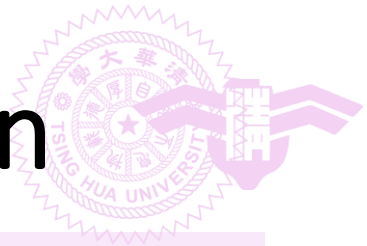

# Data Structure Design Decision

- For storing all equivalence pairs (i, j)
  - n×n array
    - e.g., `bool pairs[n][n]`
    - Result in  $\Theta(n^2)$  time complexity
  - Chain representation

$0 \equiv 4, 3 \equiv 1, 6 \equiv 10,$   
 $8 \equiv 9, 7 \equiv 4, 6 \equiv 8,$   
 $3 \equiv 5, 2 \equiv 11, 11 \equiv 0$

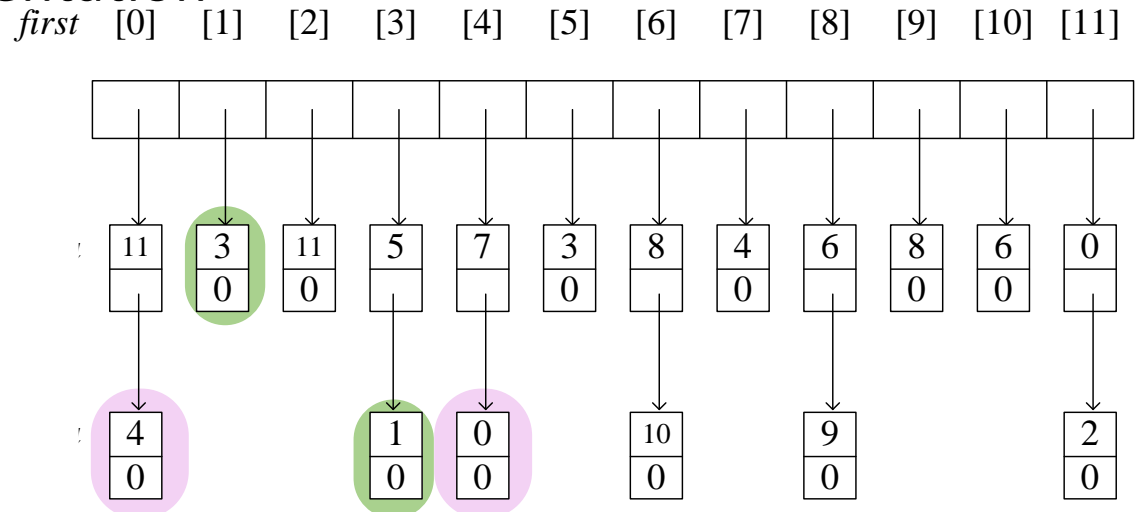

- n-element array, e.g., `bool out[n]`, is used for recording whether objects are output



# Example

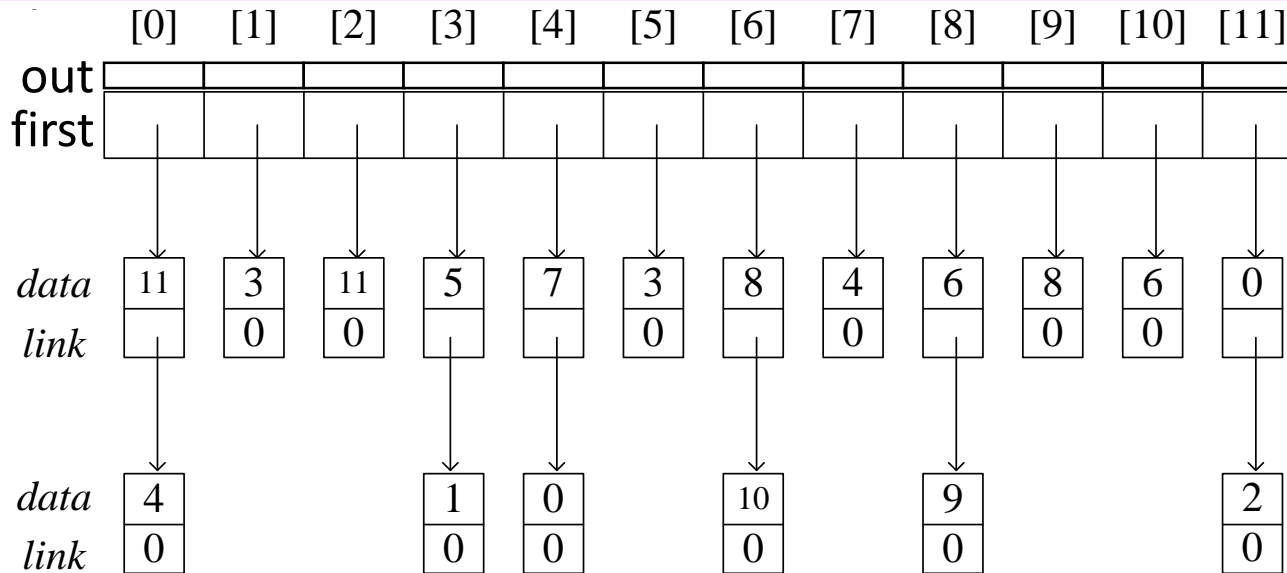

- |    |                             |           |   |
|----|-----------------------------|-----------|---|
| 1. | (Begin at 0)                |           | (Add 0 into a container, e.g., a stack) |
| 2. | (Get 0 from the container)  | Output 0  | (Add 11 and 4 into the stack)           |
| 3. | (Get 4 from the container)  | Output 4  | (Add 7 into the stack)                  |
| 4. | (Get 7 from the container)  | Output 7  | (No new objects are found)              |
| 5. | (Get 11 from the container) | Output 11 | (Add 2 into the stack)                  |
| 6. | (Get 2 from the container)  | Output 2  | (No new objects found)                  |

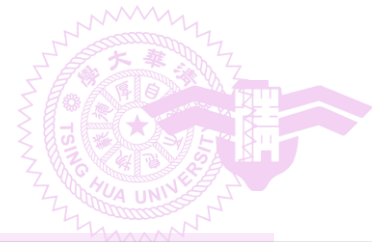

# Algorithm in C++

```
void Equivalence( )
{
    ifstream inFile("equiv.in", ios::in);
    if (!inFile) throw "Cannot open input file.";
    int i, j, n;
    inFile >> n; // number of objects
    // initialize first and out
    bool *out = new bool[n]; // an array of bool
    ENode **first = new ENode* [n]; // an array of pointers
    // use STL function fill to initialize
    fill (first, first + n, 0);
    fill (out, out + n, false);

    // Phase 1: input equivalence pairs
    inFile >> i >> j;
    while (inFile.good()) { //check end of file
        first[i] = new ENode (j, first[i])
        first[j] = new ENode (i, first[j])
        inFile >> i >> j;
    }
}
```

```

for (i = 0; i < n; i++) // Phase 2
  if (!out[i]) { // this object has not been output yet
    cout << endl << "A new class: " << i;
    out[i] = true; // mark the object
    stack<ENode> s; // initialize a stack
    ENode *x = first[i]; // obtain the ith list
    while (1) { // continue processing lists and the stack
      while (x) { // continue processing a list
        j = x->data;
        if (!out[j]) {
          cout << ", " << j;
          out[j] = true;
          s.push(*x); // add *x into the stack
        }else{
          x = x->link;
        }
      } // end of while(x)
      if (s.isEmpty()) break;
      x = s.top();
      s.pop(); // unstack
    } // end of while(1)
  } // end of if (!out[i])

```

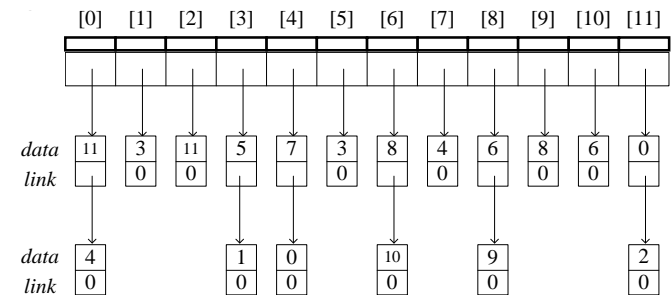



# Algorithm in C++ (cont'd)

```
for (i = 0; i < n; i++) // clean up Phase-1-created objected
    while (first[i]) {
        ENode *delnode = first[i];
        first[i] = delnode->link;
        delete delnode;
    }
delete [] first;
delete [] out;
```

- Time complexity =  $O(m+n)$ 
  - Initialization of `first[]` and `out[]` takes  $O(n)$  time
    - where  $n$  is the number of objects
  - Processing of each input pair in phase takes  $O(m)$ 
    - where  $m$  is the number of input pairs
  - The **for** loop takes  $O(n)$  time
  - Evaluating of the  $2m$  pairs takes  $O(m)$  time



# Outline

---

- 4.1-4.3 Basic singly linked lists and chains
- 4.4-4.5 Circular lists
- **4.6-4.9** Linked stacks, queues, polynomials, equivalence classes, and **sparse matrices**
- 4.10 Doubly linked lists
- 4.11 Generalized lists





# Sparse Matrices

- Array-based representation (we have learned this before)
  - Row access is easy, but column access is difficult
- Linked representation
  - Easy access both by row and column
- Node design (head field will not be shown later)

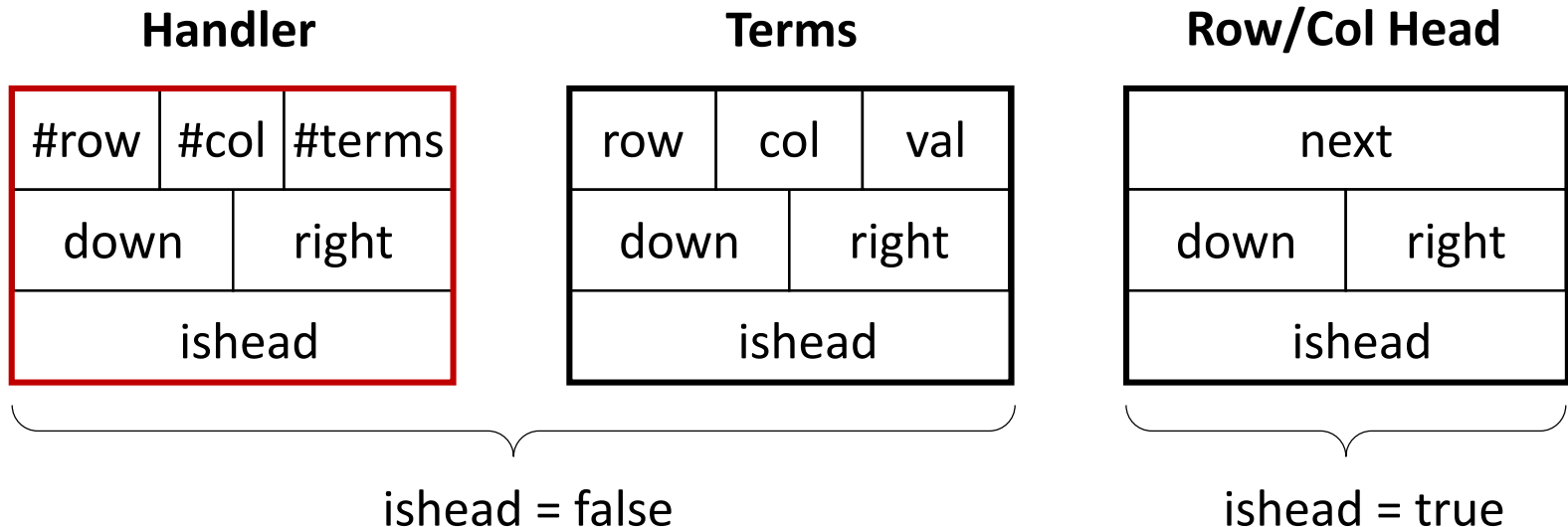



# Linked Sparse Matrix

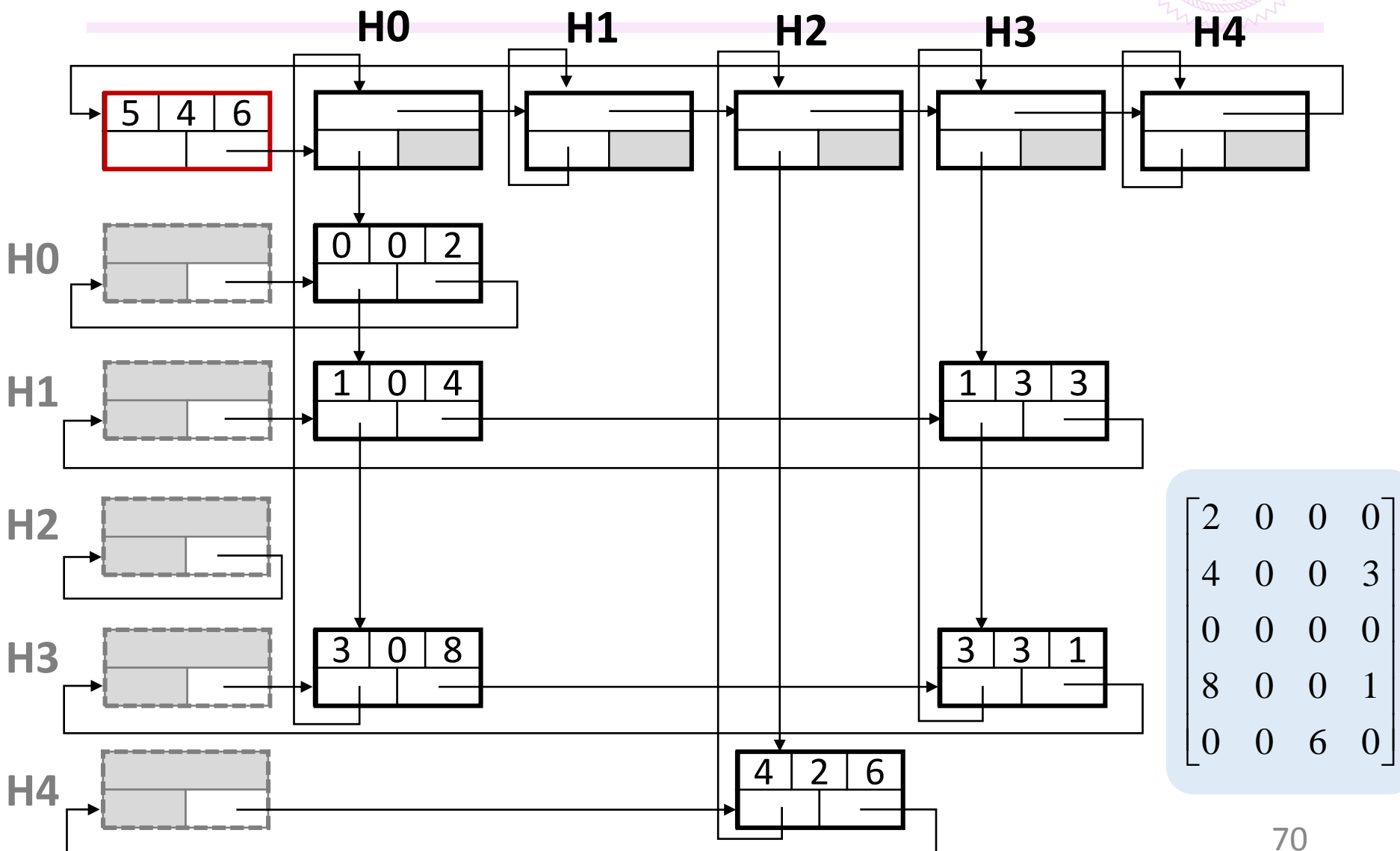

# Figure Explanations

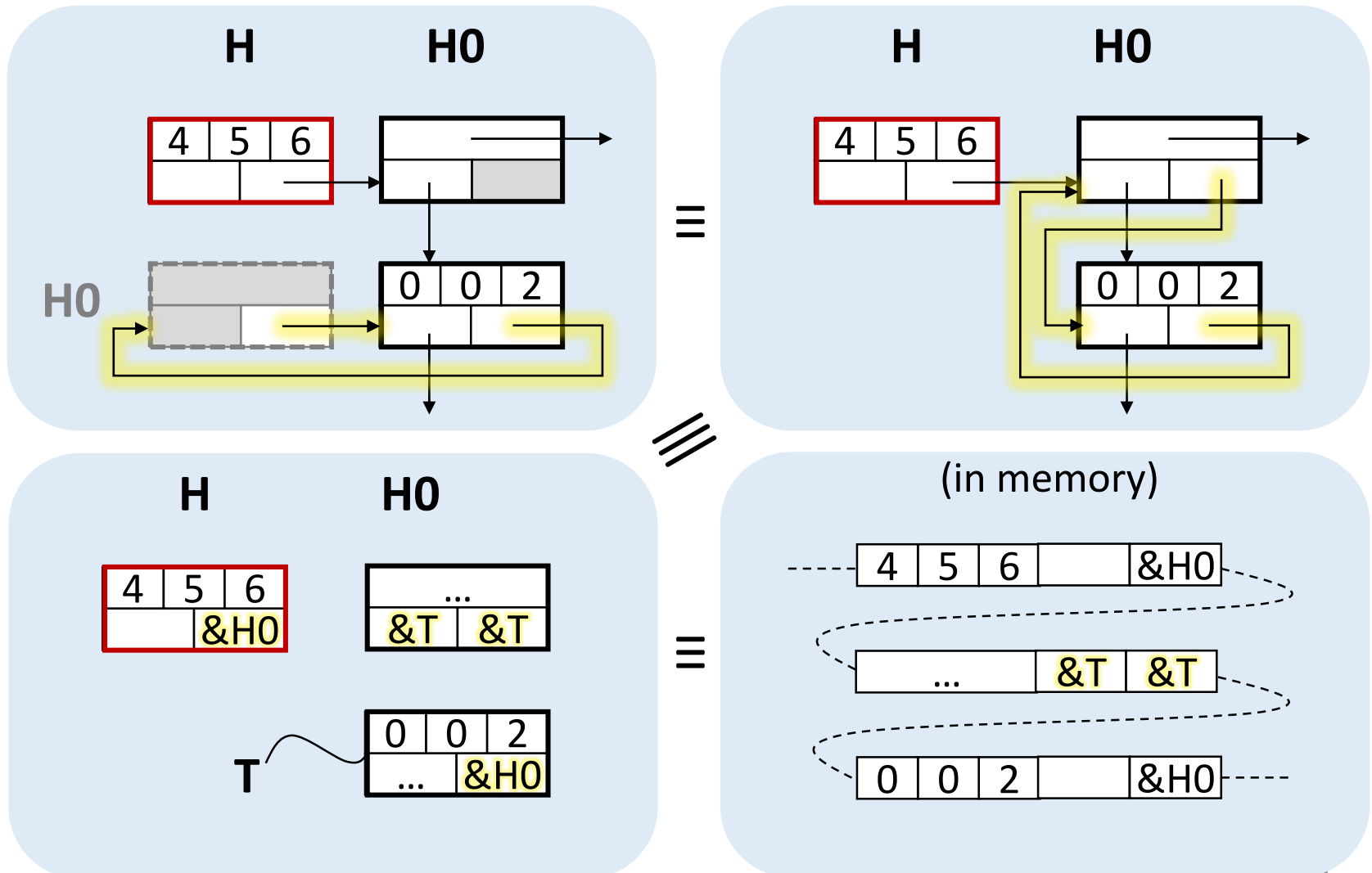

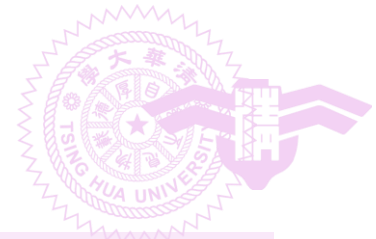

# Sparse Matrix Definition

```
struct Triple{
    int row, col, value;
};

class Matrix; // forward declaration

class MatrixNode {
friend class Matrix;
friend istream& operator>>(istream&, Matrix&);
// for reading in a matrix
private:
    MatrixNode *down , *right;
    bool head;
    union {
        MatrixNode *next;
        Triple triple;
    };
    MatrixNode(bool, Triple*); // constructor
}
```

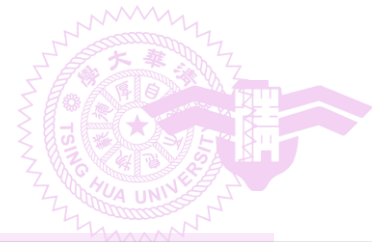

# Sparse Matrix Definition

```
MatrixNode::MatrixNode(bool b, Triple *t) // constructor
{
    head = b;
    if (b) { // row/column header node
        right = down = this;
    } else {
        triple = *t; // element node
    }
}

class Matrix{
friend istream& operator>>(istream&, Matrix&);
public:
    ~Matrix(); // destructor
private:
    MatrixNode *headnode;
};
```



# Sparse Matrix Input

- Overloading the >> operator makes **sparse matrix** more like **built-in types**

```
int i, j, k;  
cin >> i >> j >> k;  
Matrix mi, mj, mk;  
cin >> mi >> mj >> mk;
```

inputs

4	5	6
0	0	2
1	0	4
1	3	3
3	0	8
3	3	1
4	2	6

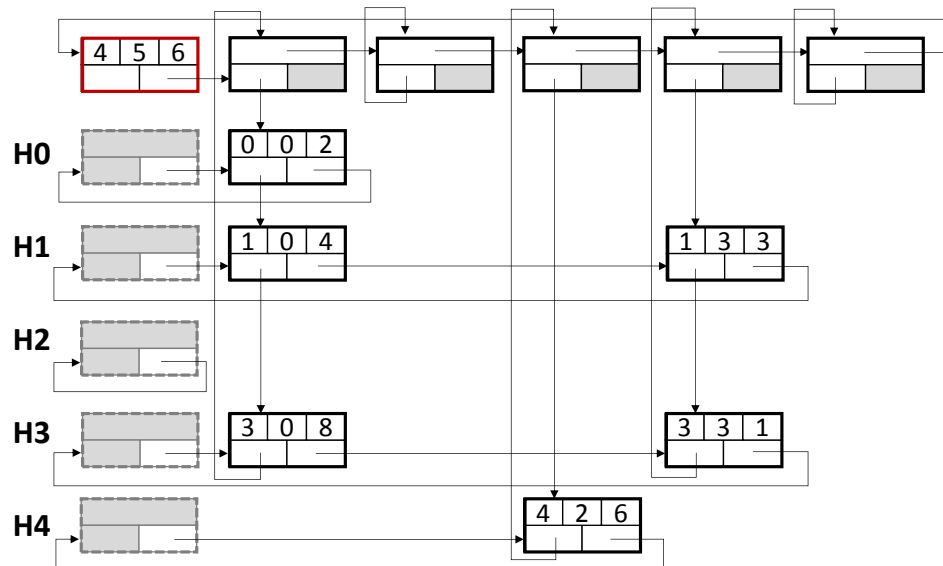

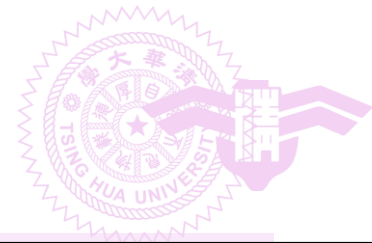

# Sparse Matrix Input

```
istream& operator>>(istream& is, Matrix& matrix)
{ // Read in a matrix and set up its linked representation
  Triple s;
  is >> s.row >> s.col >> s.value; // matrix dimensions
  int p = max(s.row, s.col);
  // set up header node for list of header nodes
  matrix.headnode = new MatrixNode(false, &s);
  if (p == 0) {
    matrix.headnode->right = matrix.headnode;
    return is; // for supporting "cin >> mi >> mj;"
  }
  // at least one row or column
  MatrixNode **head = new MatrixNode* [p];
  for (int i = 0; i < p; i++)
    head[i] = new MatrixNode(true, 0);

  // please continue on the next page
```

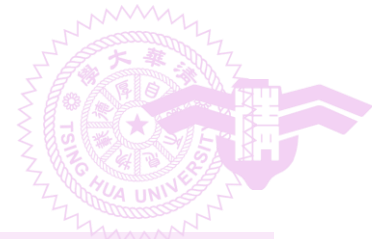

# Sparse Matrix Input

```
int currentRow = 0;
int MatrixNode *last = head[0]; // last node in current row
for (i = 0; i < s.value; i++) // input triples
{
    Triple t;
    is >> t.row >> t.col >> t.value;
    if (t.row > currentRow) { // end of current row
        last->right = head[currentRow]; // close current row
        currentRow = t.row;
        last = head[currentRow];
    } // end of if

    last = last->right = new MatrixNode(false, &t);
    // link new node into row list

    head[t.col]->next = head[t.col]->next->down = last;
    // link into column list
} // end of for
// please continue on the next page
```



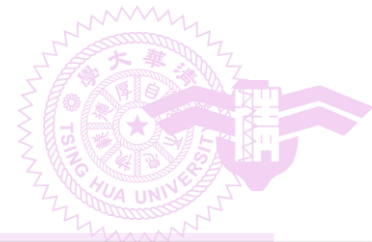

# Sparse Matrix Input

```
last->right = head[currentRow]; // close last row
for (i = 0; i < s.col; i++)
    head[i]->next->down = head[i] // close all column lists

// link the header nodes together
for (i = 0; i < p; i++)
    head[i]->next = head[i + 1];
head[p-1]->next = matrix.headnode;
matrix.headnode->right = head[0];

delete [] head;
return is;
}
```

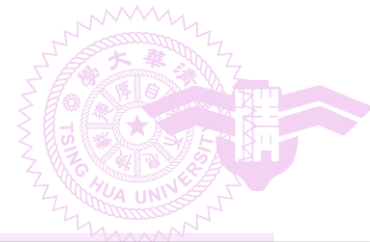

# Sparse Matrix Deletion

```
Matrix::~~Matrix()
{
    // Return all nodes to the av list, which is a chain linked
    // via the right field.
    // av is a static variable pointing to the first of the av list.
    if (!headnode )
        return; // no nodes to delete
    MatrixNode *x = headnode->right;

    headnode->right = av;
    av = headnode; // return headnode

    while (x != headnode) { // return nodes by rows
        MatrixNode *y = x->right;
        x->right = av;
        av = y;
        x = x->next; // next row
    }
    headnode = 0;
}
```



# Outline

---

- 4.1-4.3 Basic singly linked lists and chains
- 4.4-4.5 Circular lists
- 4.6-4.9 Linked stacks, queues, polynomials, equivalence classes, and sparse matrices
- **4.10 Doubly linked lists**
- 4.11 Generalized lists



# Doubly Linking vs. Singly Linking

- Doubly linked
  - Each node contain pointers to the both direction
  - Traversal can be performed in both direction

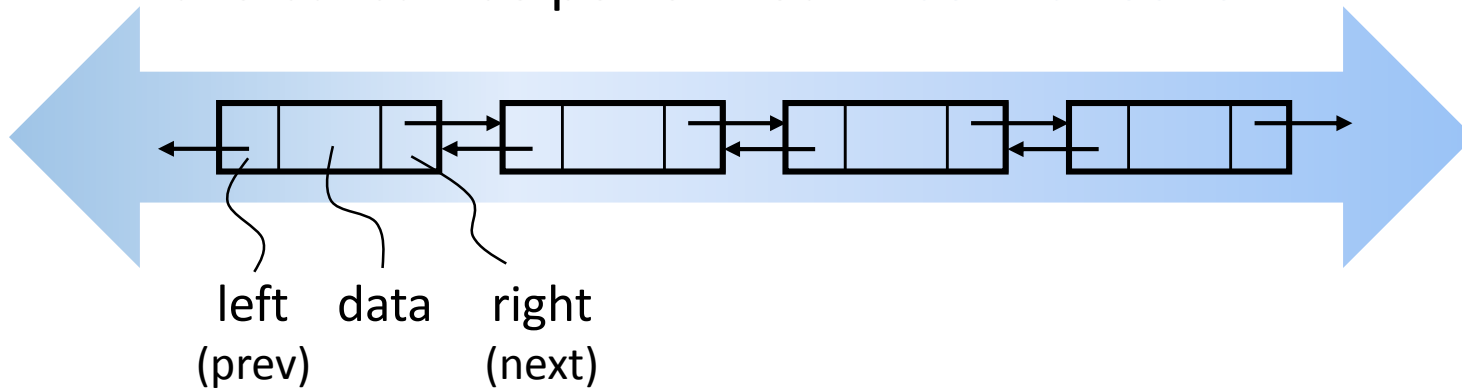

- Singly linked
  - Traversal can only be performed in one direction

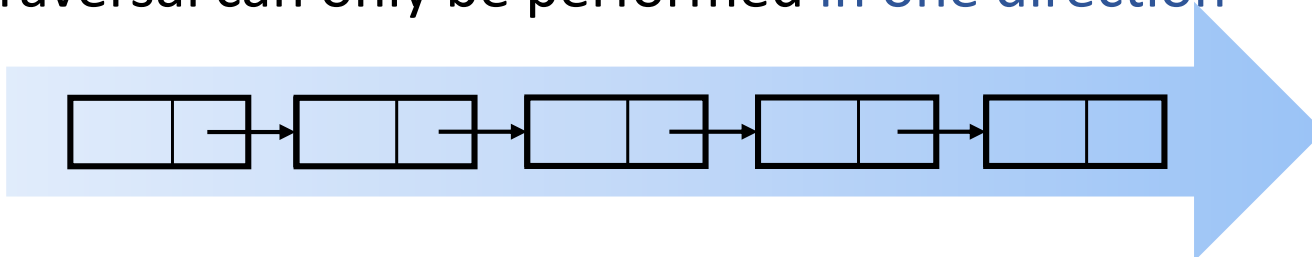



# Circular, Doubly Linked Lists with Header

- Empty list

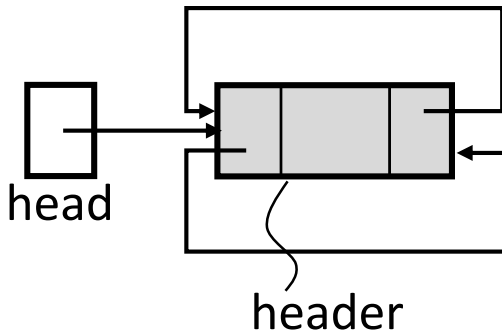

- Non-empty list

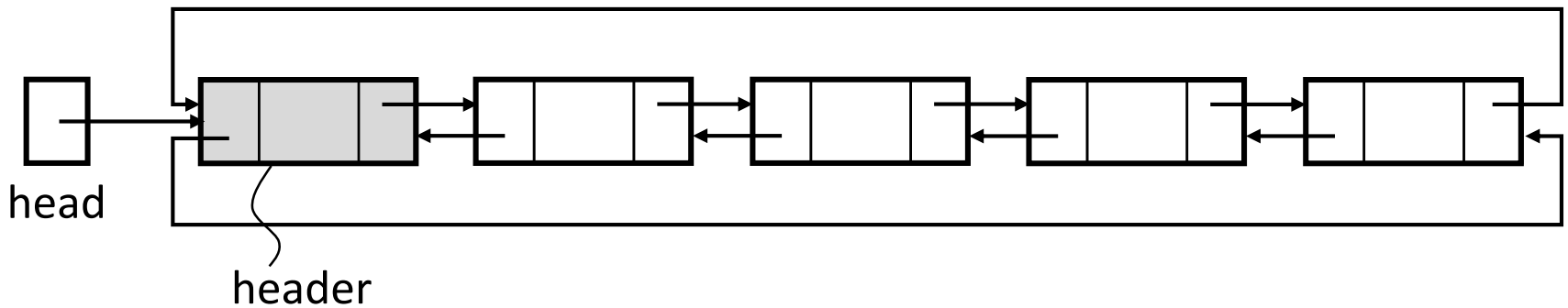



# Doubly Linked List Definition

```
class Dbllist; //forward declaration
```

```
class DbllistNode {  
friend class Dbllist;  
private:  
    int data;  
    DbllistNode * left, * right;  
};
```

Please note the syntax for declaring two pointers a line

```
class Dbllist {  
public:  
    // List manipulation operations  
    .  
    .  
private:  
    DbllistNode *head; // points to header node  
};
```

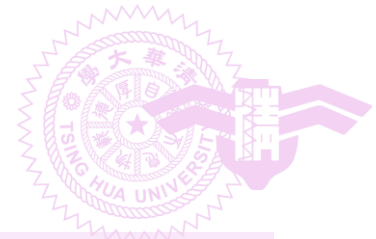

# Insertion Operation

```
void DbList :: Insert(DbListNode *p, DbListNode *x)  
{ // insert node p to the right of node x  
  p->left = x;           ①  
  p->right = x->right;   ②  
  x->right->left = p;    ③  
  x->right = p;          ④  
}
```

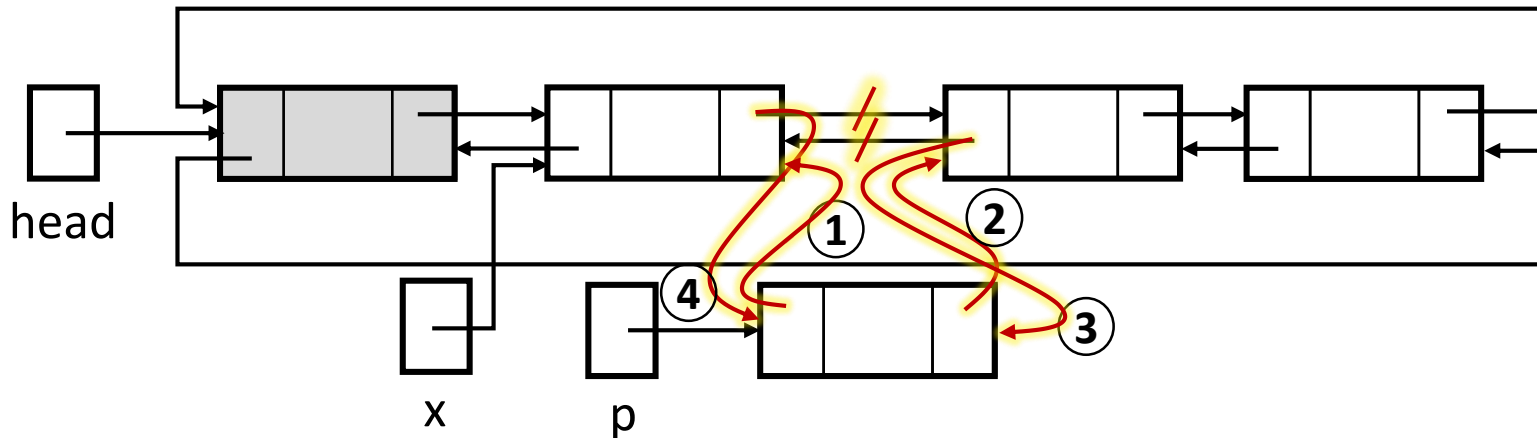

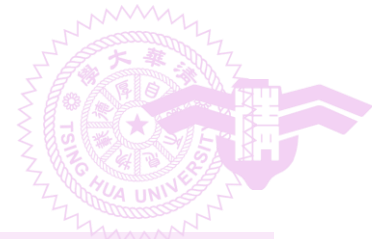

# Deletion Operation

```
void DbList :: Delete(DbListNode *x)
{
  if (x == head)
    throw "Deletion of header node not permitted";
  else {
    x->left->right = x->right; ①
    x->right->left = x->left; ②
    delete x;
  }
}
```

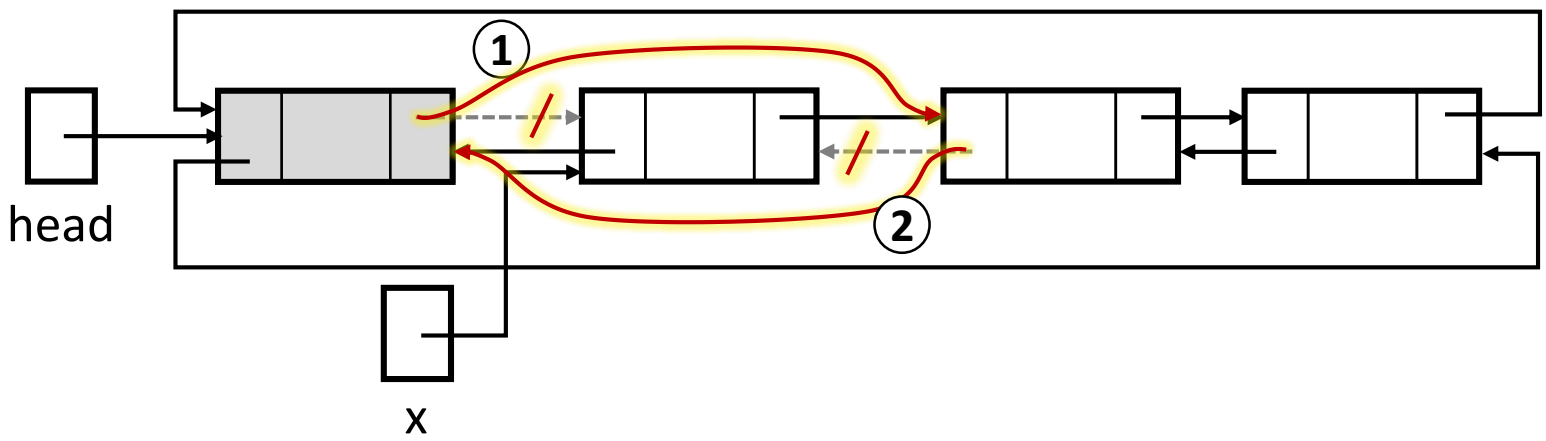





# Outline

---

- 4.1-4.3 Basic singly linked lists and chains
- 4.4-4.5 Circular lists
- 4.6-4.9 Linked stacks, queues, polynomials, equivalence classes, and sparse matrices
- 4.10 Doubly linked lists
- **4.11 Generalized lists**



# Generalized Lists

---

- Generalized list
  - Finite sequence of  $n \geq 0$  elements,  $(a_0, \dots, a_n)$ , where  $a_i$  is either an atom or a list
- Head
  - $a_0$
- Tail
  - $(a_1, \dots, a_n)$



# Examplimg Generalized Lists

- **A** = ()
  - **Empty** (also referred to as **null**) list
  - Length is zero
- **B** = (a, (b, c))
  - Length is two
  - First element is the atom a
  - Second element is the list (b, c)
- **C** = (**B**, **B**, ())
  - Length is three
  - First two elements are the list B
  - Third element is the empty list
- **D** = (a, **D**)
  - Recursive definition
  - Corresponds to the infinite list (a, (a, (a, ...)))



# Examplimg Generalized Lists

- **A** = ()
  - **B** = (a, (b, c))
  - **C** = (**B**, **B**, ())
  - **D** = (a, **D**)
- 
- head(**B**) = a
  - tail(**B**) = ((b, c))
  - head( tail(**B**) ) = (b, c)
  - tail( tail(**B**) ) = ()
- 
- head(**C**) = **B**
  - tail(**C**) = (**B**, ())



# Generalized-List Polynomials

- Example

- $x^{10}y^3z^2 + 2x^8y^3z^2 + 3x^8y^2z^2 + x^4y^4z + 6x^3y^4z + 2yz$

- Factorizing out variables

- $x^{10}y^3z^2 + 2x^8y^3z^2 + 3x^8y^2z^2 + x^4y^4z + 6x^3y^4z + 2yz$

- $= (x^{10}y^3 + 2x^8y^3 + 3x^8y^2)z^2 + (x^4y^4 + 6x^3y^4 + 2y)z$

- $= \underline{((x^{10} + 2x^8)y^3 + 3x^8y^2)z^2} + \underline{((x^4 + 6x^3)y^4 + 2y)z}$

||

$$\underline{C(x, y)z^2} + \underline{D(x, y)z}$$

//

≡

$$\underline{E(x)y^3 + F(x)y^2}$$

$$\underline{G(x)y^4 + G(x)y}$$



# Generalized-List Polynomials

- $((x^{10} + 2x^8)y^3 + 3x^8y^2)z^2 + ((x^4 + 6x^3)y^4 + 2y)z$
- Three types of information
  - Factored-out variable e.g., 'z'
  - Exponent of the factored variable and a link to the associated sub-polynomial e.g., 2  $(x^{10} + 2x^8)y^3 + 3x^8y^2$
  - Coefficient of each term e.g., 1
- Node structure for storing the information

type of the node
variable name / link to sub-polynomial / coefficient
exponent (optional)
link to the next node



# Generalized-List Polynomials

- $((x^{10} + 2x^8)y^3 + 3x^8y^2)z^2 + ((x^4 + 6x^3)y^4 + 2y)z$

$$3x^8 \quad \boxed{x \mid 0 \mid -} \rightarrow \boxed{3 \mid 8 \mid 0}$$

$$x^{10} + 2x^8 \quad \boxed{x \mid 0 \mid -} \rightarrow \boxed{1 \mid 10 \mid -} \rightarrow \boxed{2 \mid 8 \mid 0}$$



# Generalized-List Polynomials

•  $((x^{10} + 2x^8)y^3 + 3x^8y^2)z^2 + ((x^4 + 6x^3)y^4 + 2y)z$

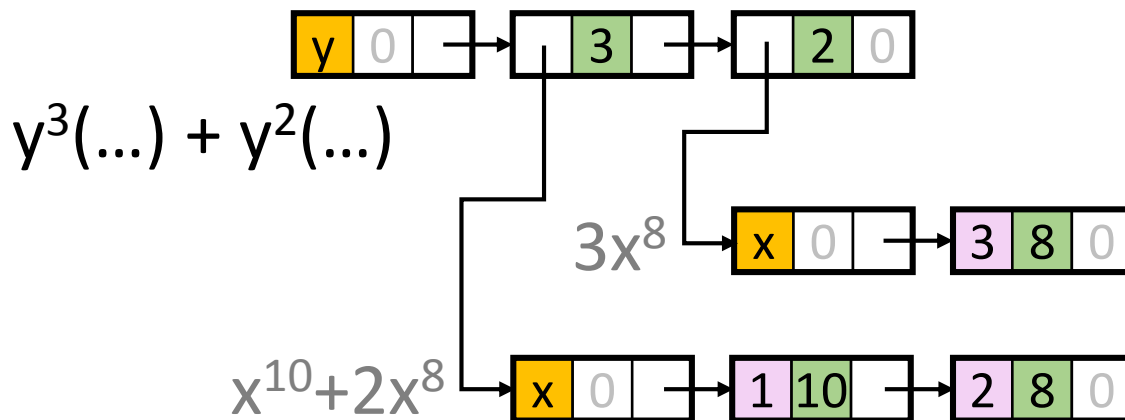





# Generalized-List Polynomials

- $((x^{10} + 2x^8)y^3 + 3x^8y^2)z^2 + ((x^4 + 6x^3)y^4 + 2y)z$

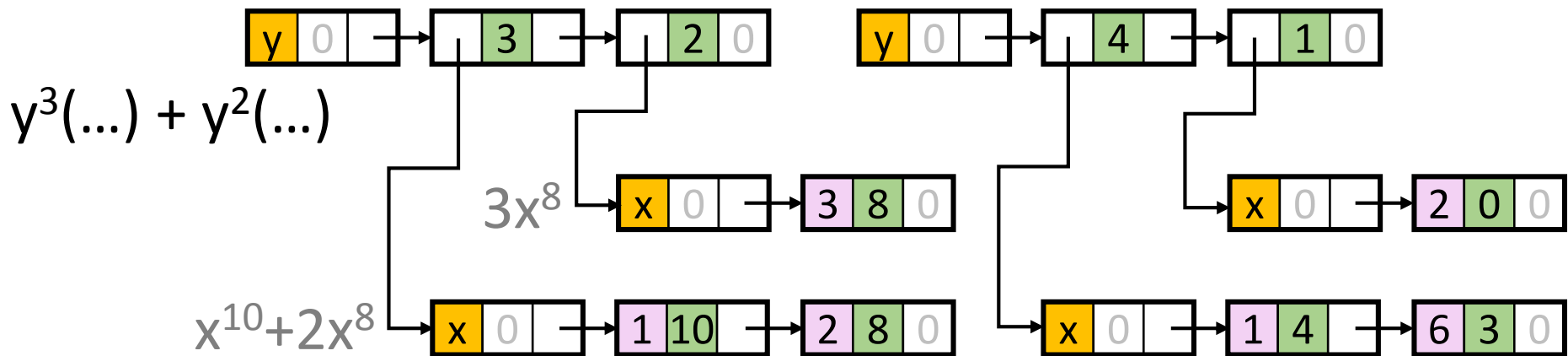



# Generalized-List Polynomials

- $((x^{10} + 2x^8)y^3 + 3x^8y^2)z^2 + ((x^4 + 6x^3)y^4 + 2y)z$

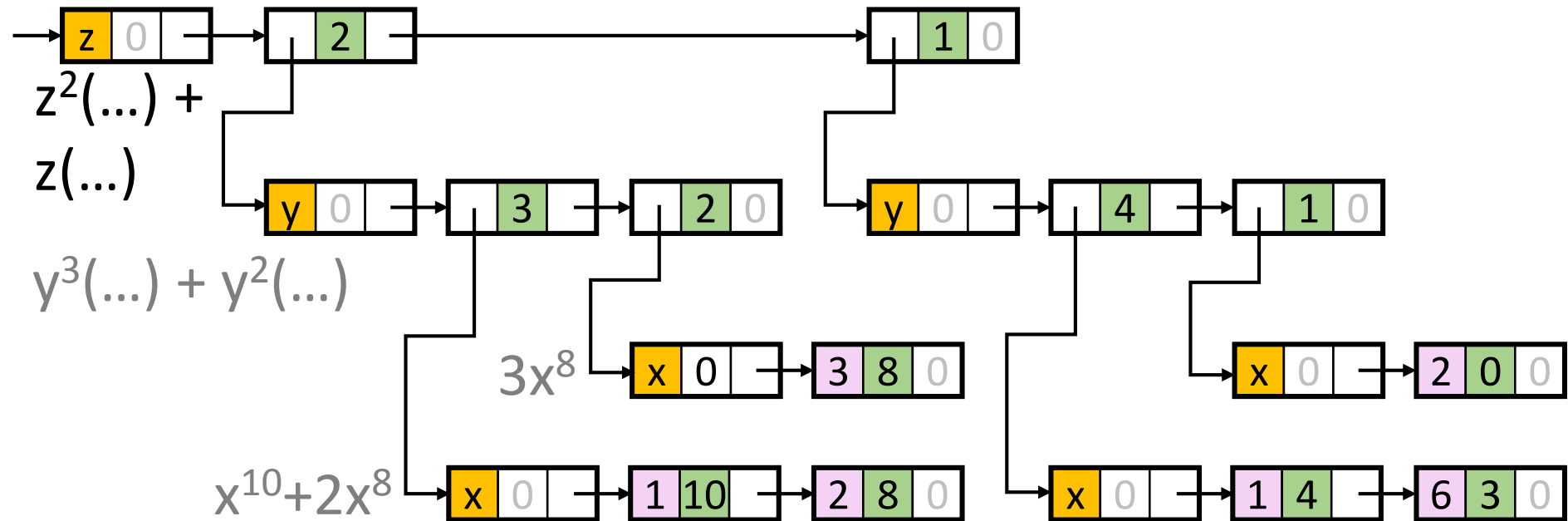

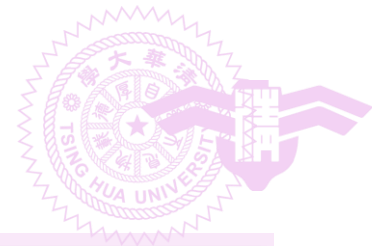

# Node Definition

```
enum NodeType{var, ptr, no}; // var=0, ptr=1, no=2
class PolyNode
{
    NodeType type;

    char name;
    PolyNode* sub;
    int coef;

    int exp;
    PolyNode* next; // link to next node
}
```

type of the node

variable name

link to sub-polynomial

coefficient

exponent (optional)

link to the next node

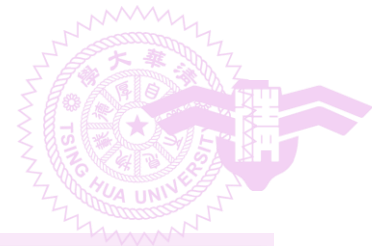

# Node Definition

```
enum NodeType{var, ptr, no}; // var=0, ptr=1, no=2
class PolyNode
{
    NodeType type;
    union{
        char name;
        PolyNode* sub;
        int coef;
    }
    int exp;
    PolyNode* next; // link to next node
}
```

// three variables overlap in memory

type of the node
name / sub / coef
exponent (optional)
link to the next node

reduced node size



# Generalized Lists

- Node structure



- **A** = ()
- **A'** = (( ))
- **B** = (a, (b, c))
- **C** = (**B**, **B**, ())
- **D** = (a, **D**)

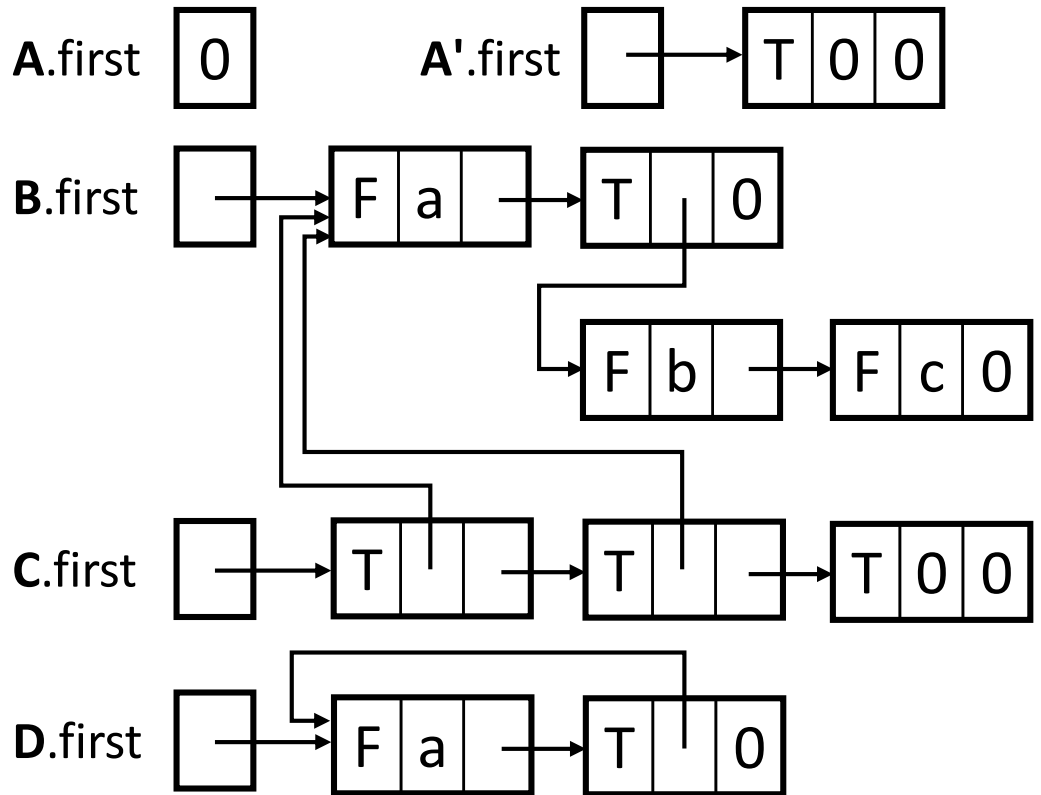

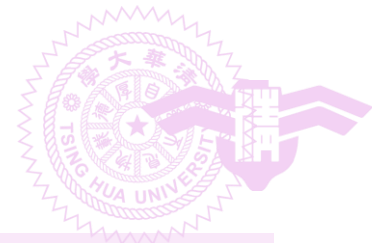

# Generalized List

```
template <class T> class GenList; // forward declaration
```

```
template <class T>
class GenListNode{
friend class GenList <T>;
private:
    GenListNode<T>* next;
    bool tag;
    union {
        T data;
        GenListNode<T>* down;
    }
}
```

```
template <class T>
class GenList{
public:
    // List manipulation operations
private:
    GenListNode<T>* first;
}
```

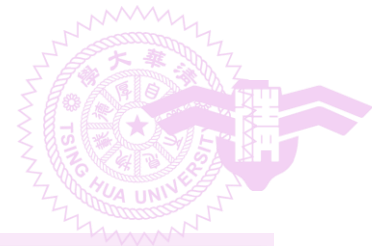

# Copying a List

```
// Driver
void GenList<T>::Copy(const GenList<T>& l)
{ // make a copy of l
    first = Copy (l.first);
}

// Workhorse
GenListNode<T>* GenList<T>::Copy(GenListNode<T>* p)
{ // Copy the nonrecursive list with no shared sublists
    GenListNode<T>*q = 0;
    if (p) {
        q = new GenListNode<T>;
        q->tag = p->tag;
        if (p->tag) q->down = Copy (p->down);
        else q->data = p->data;
        q->next = Copy(p->next);
    }
    return q;
}
```

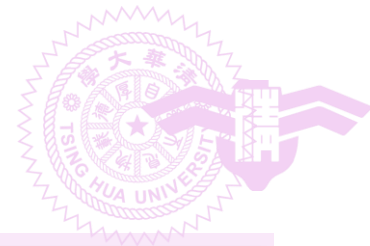

# Testing Equality for Two Lists

```
// Driver
template<class T>
bool operator == (const GenList<T>& l) const
{ // *this and l are non-recursive lists
  // return true iff the two lists are identical
  return Equal (first, l.first);
}

// Workhorse
bool Equal(GenListNode<T>*s, GenListNode<T>*t)
{
  if ((!s) && (!t)) return true;
  if (s && t && (s->tag == t->tag))
    if (s->tag)
      return Equal(s->down, t->down)&&Equal(s->next, t->next);
    else
      return (s->data == t->data)&&Equal(s->next, t->next);
  return false;
}
```



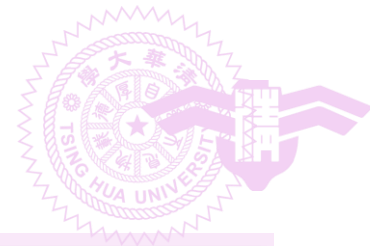

# Computing the List Depth

```
// Driver // Depth  $\equiv$  max degree of nested sublists
template <class T>
int GenList<T>::Depth()
{ // Compute the depth of a non-recursive list
  return Depth(first);
}
// Workhorse
template <class T>
int GenList::Depth(GenListNode<T>* s)
{
  if (!s) return 0; // empty list
  GenListNode<T>* current = s;
  int m=0; // initial minimum value
  while (current) {
    if (current->tag) m = max(m, Depth(current->down));
    current = current->next;
  } // m is the max depth among sublists
  return m+1;
}
```



# Computing the List Depth

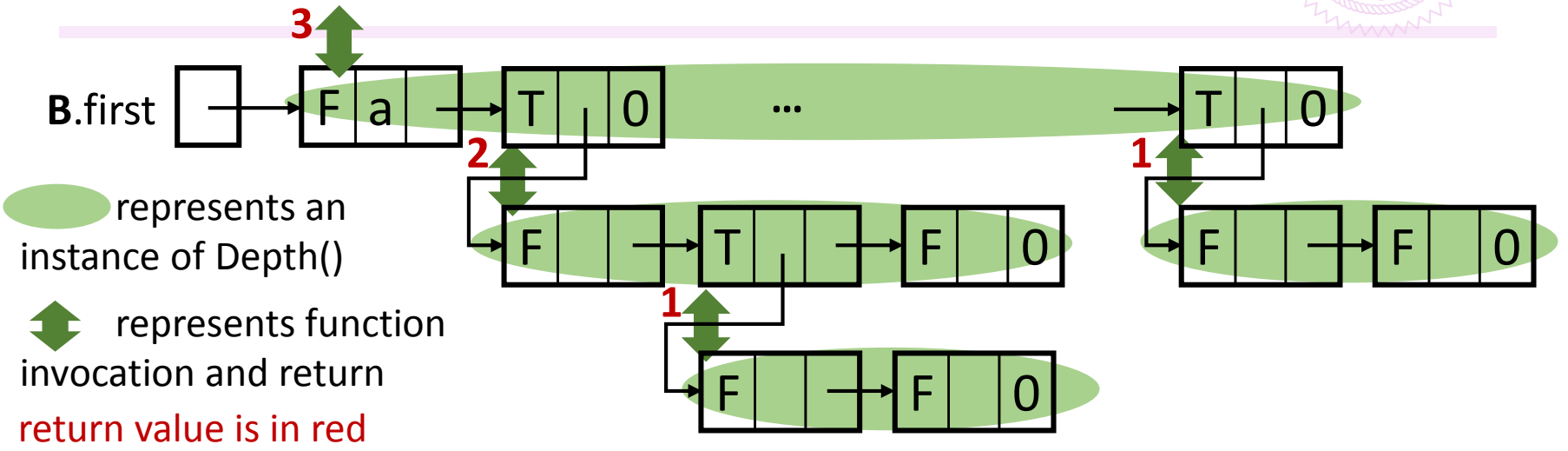

```

template <class T>
int GenList::Depth(GenListNode<T>* s)
{
  if (!s) return 0; // empty list
  GenListNode<T>* current = s;
  int m=0;
  while (current) {
    if (current->tag) m = max(m, Depth(current->down));
    current = current->next;
  } // m is the max depth among sublists (m=0 if no sublists exist)
  return m+1; // increments m for the current list
}
  
```



# Adding a Node or Deleting a Lists

- Design issues
  - **Adding or deleting node** at the front of a list can affect the *down* fields of other lists
    - e.g., adding an 'x' in front of 'a' in **B**
    - We normally do not know these affected fields
  - Determining whether list nodes need to be freed
    - e.g., the node 'a' needs to be kept (if other lists require it) even if B.first no longer points to it

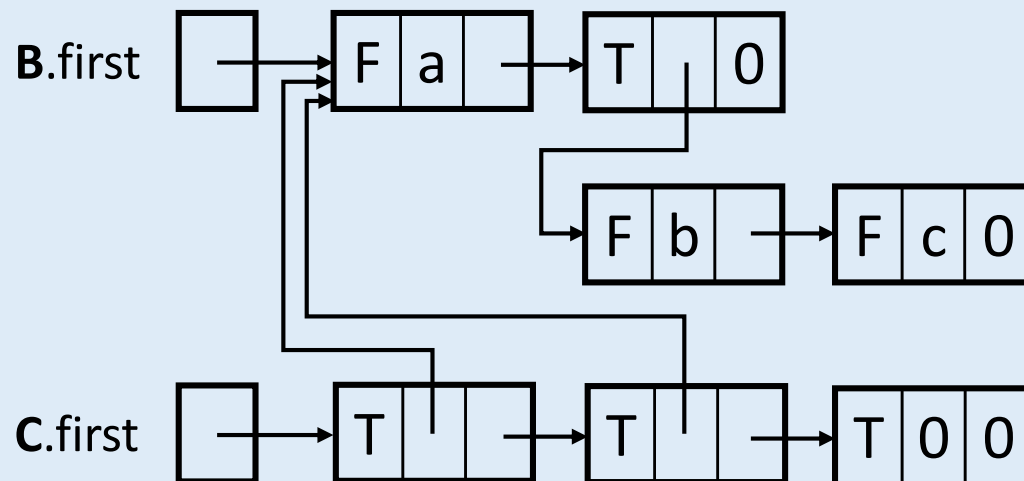

# Headers and Reference Counts

---

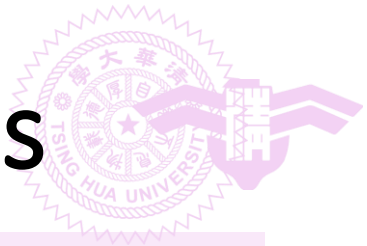

- Each list/sublist equips a header
  - Adding and deleting node at the front of the list does not affect other lists
- Headers serve the reference point of a list
- Header tracks the reference count, the number of pointers pointing to the lists
  - List nodes with no reference to them require being freed

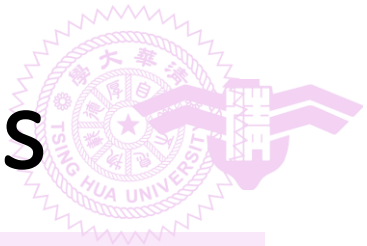

# Headers and Reference Counts

- **A** = ()
- **B** = (a, (b, c))
- **C** = (**B**, **B**, ())
- **D** = (a, **D**)

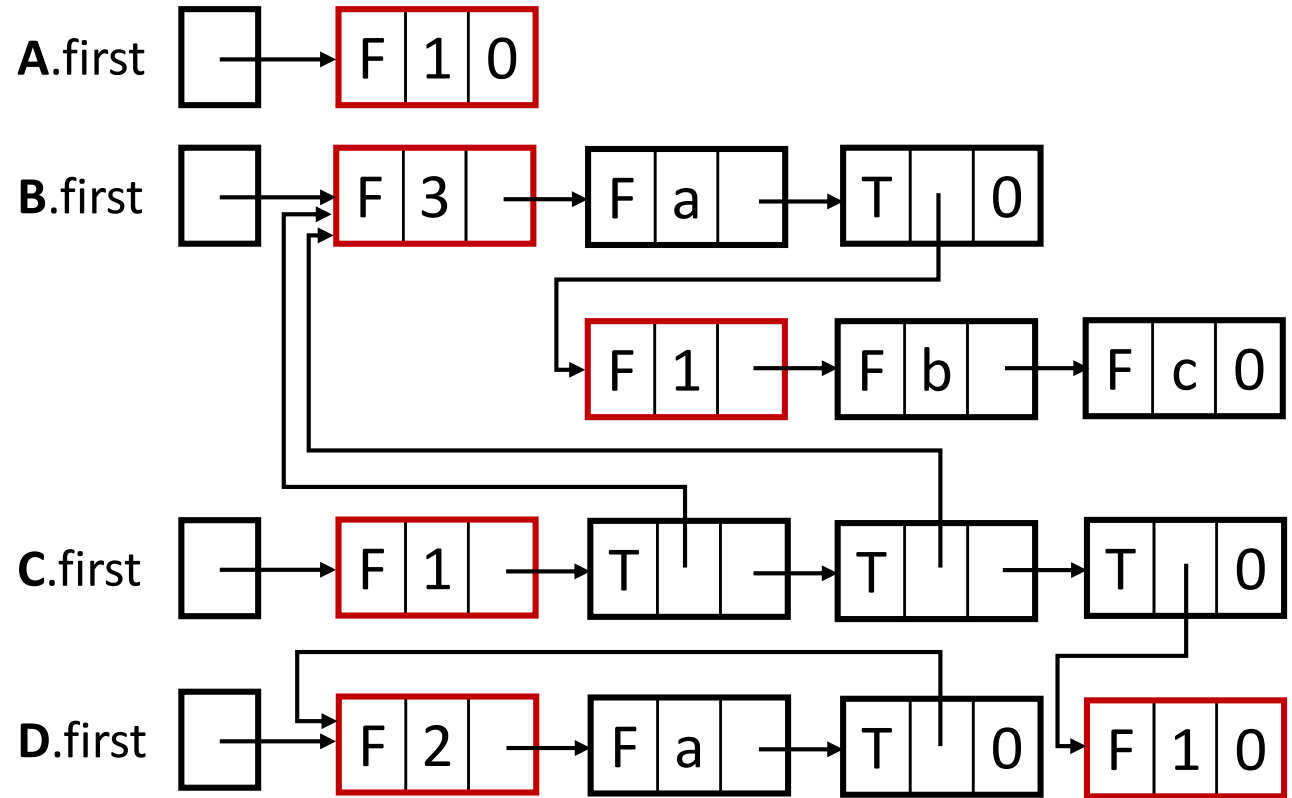

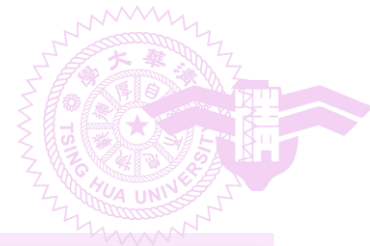

# Deleting Generalized Lists

```
// Driver
template <class T>
GenList<T>::~~GenList() // Destructor
{ // Each header node has a reference count
    if (first){
        Delete(first);
        first = 0;
    }
}
// Workhorse
void GenList<T>::Delete(GenListNode<T>* x)
{
    x->ref--; // decrement reference count of header node
    if (!x->ref){
        GenListNode<T> *y = x;
        while (y->next) // y traverses top level of x
        { y = y->next; if (y has down link) Delete(y->down); }
        y->next = av; // attach top-level nodes to av list
        av = x;
    }
}
```