

Chapter 6

Parallel Processors from Client to Cloud

Introduction

- Goal: connecting multiple computers to get higher performance
 - Multiprocessors
 - Scalability, availability, power efficiency
- Task-level (process-level) parallelism
 - High throughput for independent jobs
- Parallel processing program
 - Single program run on multiple processors
 - Multicore microprocessors --- chips with multiple processors (cores)

Hardware and Software

- Hardware
 - Serial: e.g., one Pentium core
 - Parallel: e.g., quad-core Xeon CPU
- Software
 - Sequential: e.g., matrix multiplication
 - Concurrent: e.g., web server
- Sequential/concurrent software can run on serial/parallel hardware
 - Challenge: making effective use of parallel hardware

What We've Already Covered

- §2.11: Parallelism and Instructions
 - Synchronization
- §3.6: Parallelism and Computer Arithmetic
 - Subword Parallelism
- §4.10: Parallelism and Advanced Instruction-Level Parallelism
- §5.10: Parallelism and Memory Hierarchies
 - Cache Coherence

Parallel Programming

- Parallel software is the problem
- Need to get significant performance improvement
 - Otherwise, just use a faster uniprocessor, since it's easier!
- Difficulties
 - Partitioning
 - Coordination
 - Communications overhead

Amdahl's Law

- Sequential part can limit speedup
- Example: 100 processors, 90× speedup?
 - $T_{\text{new}} = T_{\text{parallelizable}}/100 + T_{\text{sequential}}$
 - $$\text{Speedup} = \frac{1}{(1 - F_{\text{parallelizable}}) + F_{\text{parallelizable}}/100} = 90$$
 - Solving: $F_{\text{parallelizable}} = 0.999$
- Need sequential part to be 0.1% of original time

Scaling Example

- Workload: sum of 10 scalars, and 10×10 matrix sum
 - Speed up from 10 to 100 processors
- Single processor: Time = $(10 + 100) \times t_{\text{add}}$
- 10 processors
 - Time = $10 \times t_{\text{add}} + 100/10 \times t_{\text{add}} = 20 \times t_{\text{add}}$
 - Speedup = $110/20 = 5.5$ (55% efficiency)
- 100 processors
 - Time = $10 \times t_{\text{add}} + 100/100 \times t_{\text{add}} = 11 \times t_{\text{add}}$
 - Speedup = $110/11 = 10$ (10% efficiency)
- Assumes load can be balanced across processors

Scaling Example (cont)

- What if matrix size is 100×100 ?
- Single processor: Time = $(10 + 10000) \times t_{\text{add}}$
- 10 processors
 - Time = $10 \times t_{\text{add}} + 10000/10 \times t_{\text{add}} = 1010 \times t_{\text{add}}$
 - Speedup = $10010/1010 = 9.9$ (99% efficiency)
- 100 processors
 - Time = $10 \times t_{\text{add}} + 10000/100 \times t_{\text{add}} = 110 \times t_{\text{add}}$
 - Speedup = $10010/110 = 91$ (91% efficiency)
- Assuming load balanced

Strong vs Weak Scaling

- **Strong scaling**: problem size fixed
 - As in example
- **Weak scaling**: problem size proportional to number of processors
 - 10 processors, 10×10 matrix
 - Time = $20 \times t_{\text{add}}$
 - 100 processors, 32×32 matrix
 - Time = $10 \times t_{\text{add}} + 1000/100 \times t_{\text{add}} = 20 \times t_{\text{add}}$
 - Constant performance in this example

Instruction and Data Streams

- An alternate classification

		Data Streams	
		Single	Multiple
Instruction Streams	Single	SISD: RISC-V Base ISA	SIMD: AVX instructions of x86; Thinking Machine CM2
	Multiple	MISD: No example	MIMD: Multi-processors: Cray T3D, TM CM5 <small>VLIW (Very Long Instruction Word)</small>

- SIMD: Single Instruction Multiple Data
- MIMD: Multiple Instruction Multiple Data
 - SPMD: Single Program Multiple Data --- a parallel program on a MIMD computer

Example: DAXPY ($Y = a \times X + Y$)

Conventional RISC-V code:

```
fld    f0,0(x3)    // load scalar a
addi   x5,x19,512  // end of array x
loop:  fld    f1,0(x19) // load x[i]
      fmul.d f1,f1,f0  // a * x[i]
      fld    f2,0(x20) // load y[i]
      fadd.d f2,f2,f1  // a * x[i] + y[i]
      fsd    f2,0(x20) // store y[i]
      addi   x19,x19,8  // increment index to x
      addi   x20,x20,8  // increment index to y
      bltu   x19,x5,loop // repeat if not done
```

Vector RISC-V code:

```
fld    f0,0(x3)    // load scalar a
fld.v  v0,0(x19)   // load vector x
fmul.d.vs v0,v0,f0 // vector-scalar multiply
fld.v  v1,0(x20)   // load vector y
fadd.d.v v1,v1,v0  // vector-vector add
fsd.v  v1,0(x20)   // store vector y
```

沒有Loop, 不用做Branch Prediction也沒有Pipeline Bubbles

Vector Processors

- Highly pipelined function units
- Stream data from/to vector registers to memory
 - Data collected from memory into registers
 - Results stored from registers to memory
- Example: Vector extension to RISC-V
 - 32 × 64-element registers (64-bit elements)
 - Vector instructions
 - `vld, vst`: load/store vector
 - `vadd`: add vectors of integers
 - `fadd.d.v`: add two vectors of doubles
- Significantly reduces instruction-fetch bandwidth and improve vector data access locality

Cray-1 (1976)

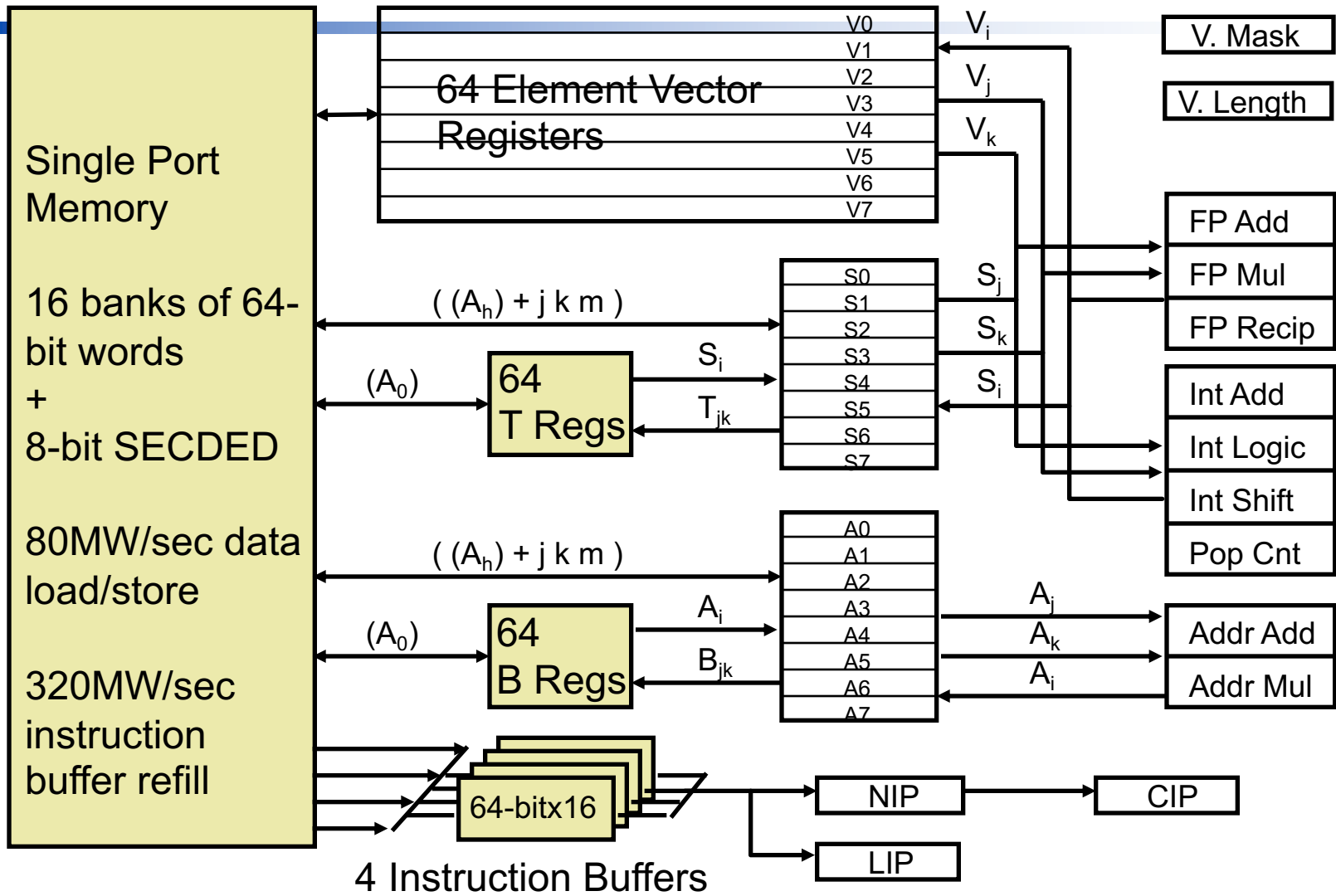

memory bank cycle 50 ns processor cycle 12.5 ns (80MHz)

Vector Programming Model

Scalar Registers

Vector Registers

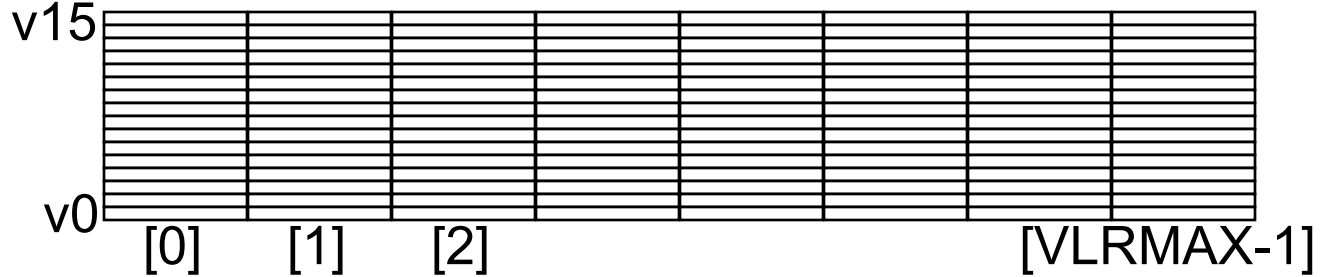
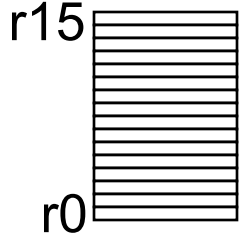

Vector Length Register

VLR

Vector Arithmetic Instructions

ADDV v3, v1, v2

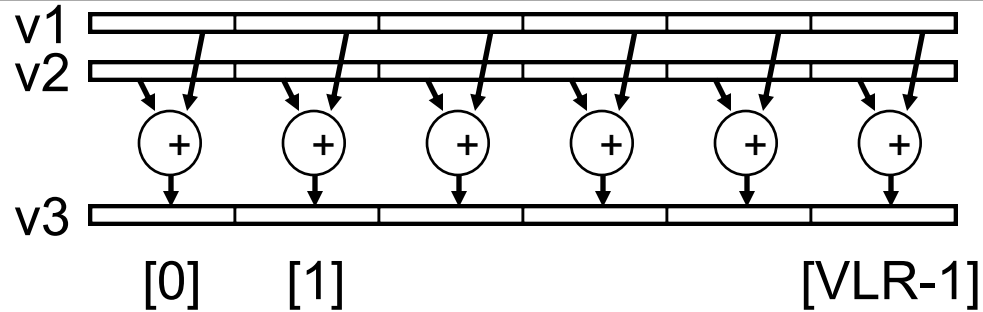

Vector Load and Store Instructions

LV v1, r1, r2

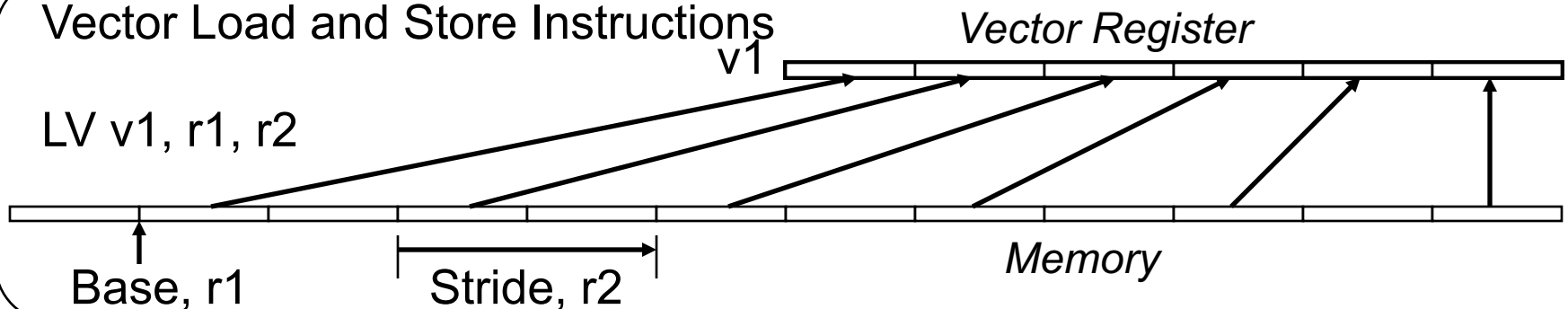

Vector Instruction Set Advantages

- Compact
 - one short instruction encodes N operations
- Expressive, tells hardware that these N operations:
 - are independent
 - use the same functional unit
 - access disjoint registers
 - access registers in the same pattern as previous instructions
 - access a contiguous block of memory (unit-stride load/store)
 - access memory in a known pattern (strided load/store)
- Scalable
 - can run same object code on more parallel pipelines or lanes

Vector Arithmetic Execution

- Use deep pipeline (\Rightarrow fast clock) to execute element operations
- Simplifies control of deep pipeline because elements in vector are independent (\Rightarrow no hazards!)



Six stage multiply pipeline

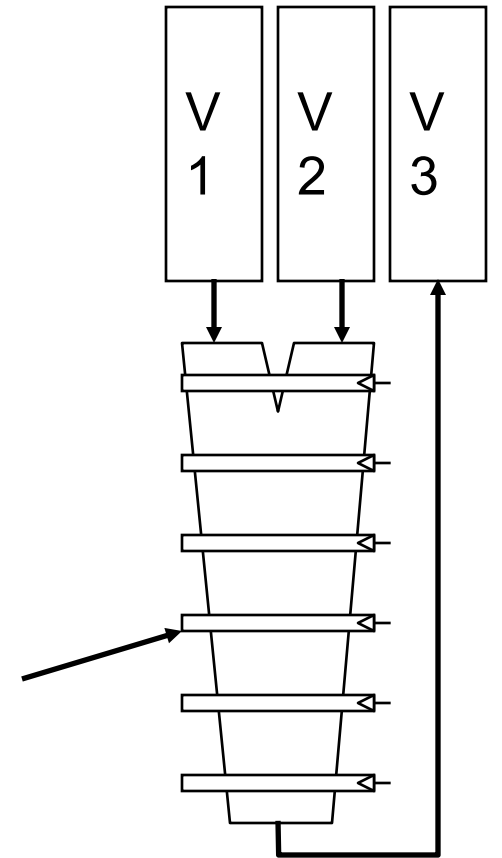

$$V3 \leftarrow v1 * v2$$

Vector Memory System

Cray-1, 16 banks, 4 cycle bank busy time, 12 cycle latency

- *Bank busy time*: Cycles between accesses to same bank

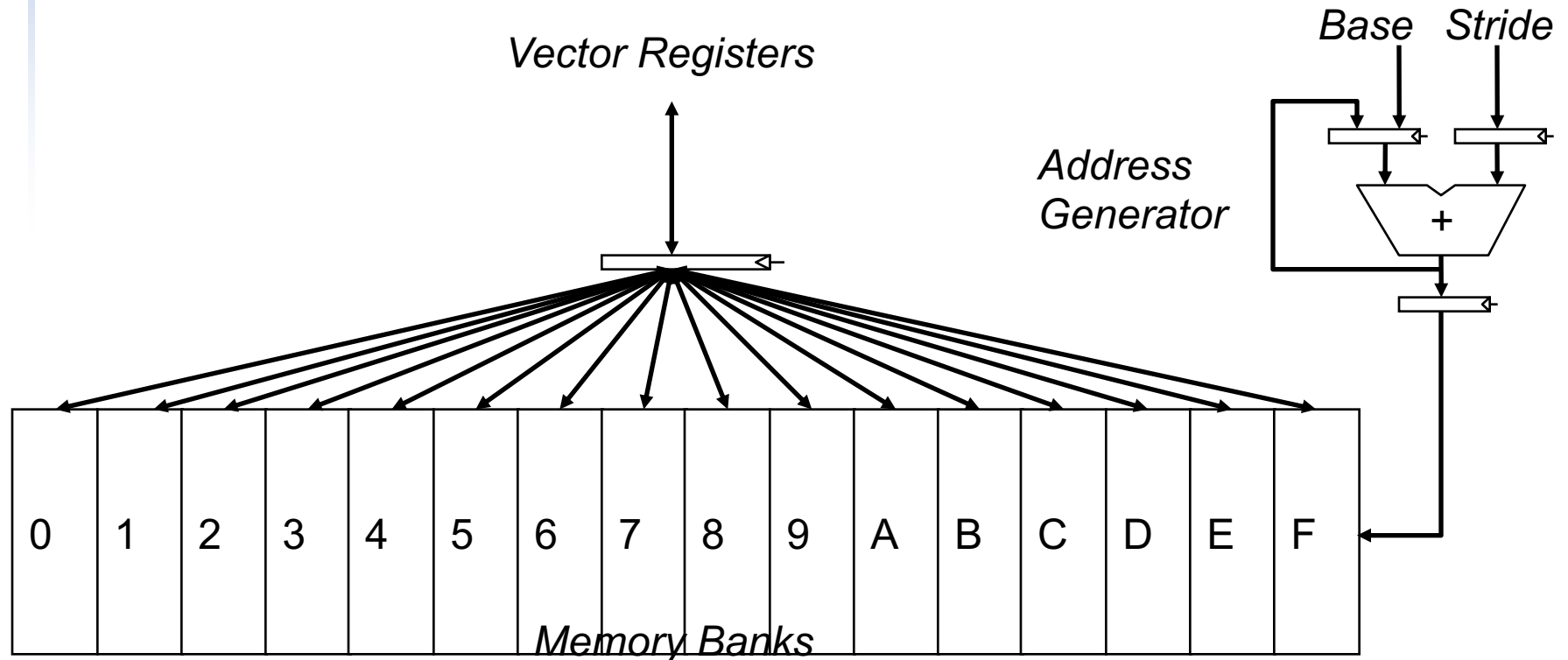

Vector Instruction Execution

ADDV C, A, B

*Execution using
one pipelined
functional unit*

*Execution using
four pipelined
functional units*

A[6] B[6]
A[5] B[5]
A[4] B[4]
A[3] B[3]

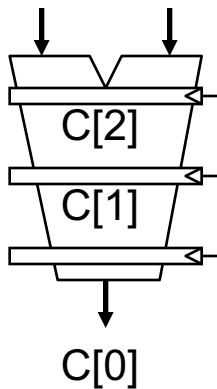

A[24] B[24] A[25] B[25] A[26] B[26] A[27] B[27]
A[20] B[20] A[21] B[21] A[22] B[22] A[23] B[23]
A[16] B[16] A[17] B[17] A[18] B[18] A[19] B[19]
A[12] B[12] A[13] B[13] A[14] B[14] A[15] B[15]

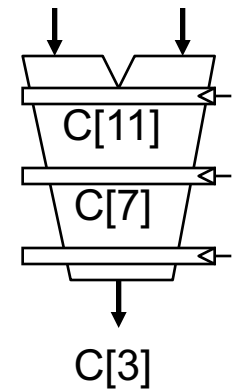
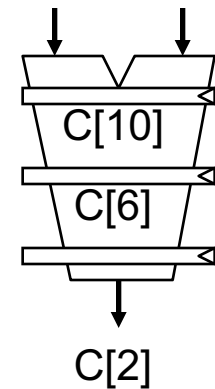
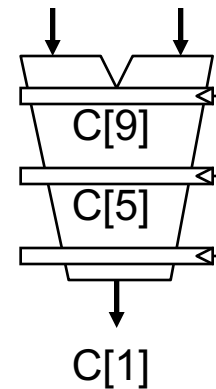
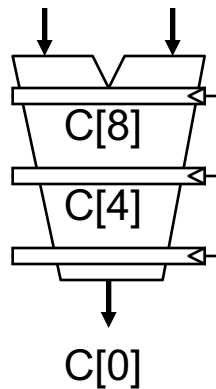

Vector vs. Scalar

- Vector architectures and compilers
 - Simplify data-parallel programming
 - Explicit statement of absence of loop-carried dependences
 - Reduced checking in hardware
 - Regular access patterns benefit from interleaved and burst memory
 - Avoid control hazards by avoiding loops
- More general than ad-hoc media extensions (such as MMX, SSE)
 - Better match with compiler technology

SIMD

- Operate elementwise on vectors of data
 - E.g., MMX and SSE instructions in x86
 - Multiple data elements in 128-bit wide registers
- All processors execute the same instruction at the same time
 - Each with different data address, etc.
- Simplifies synchronization
- Reduced instruction control hardware
- Works best for highly data-parallel applications

Vector vs. Multimedia Extensions

- Vector instructions have a variable vector width, multimedia extensions have a fixed width
- Vector instructions support strided access, multimedia extensions do not
- Vector units can be combination of pipelined and arrayed functional units:

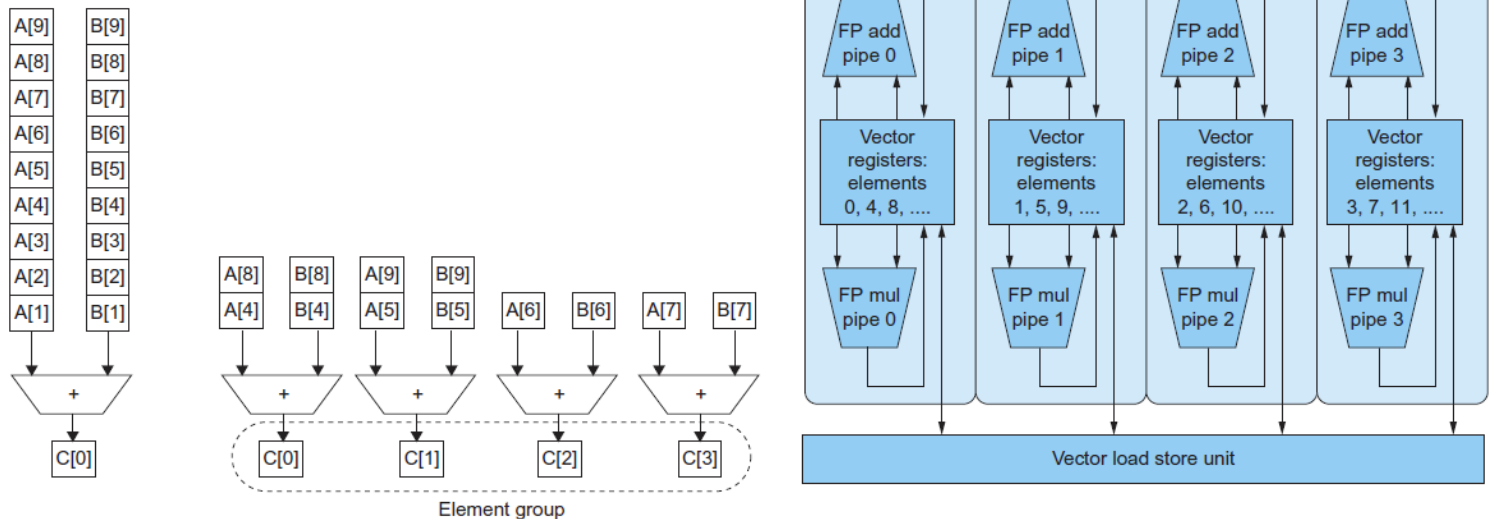

Multithreading

- Performing **multiple threads** of execution in parallel
 - Replicate registers, PC, etc.
 - Fast switching between threads
- **Fine-grain** multithreading
 - Switch threads after each cycle
 - Interleave instruction execution
 - If one thread stalls, others are executed
- **Coarse-grain** multithreading
 - Only switch on long stall (e.g., L2-cache miss)
 - Simplifies hardware, but doesn't hide short stalls (eg, data hazards)

Simultaneous Multithreading

- In multiple-issue dynamically scheduled processor
 - Schedule instructions from multiple threads
 - Instructions from independent threads execute when function units are available
 - Within threads, dependencies handled by scheduling and register renaming
- Example: Intel Pentium-4 HT
 - Two threads: duplicated registers, shared function units and caches

Multithreading Example

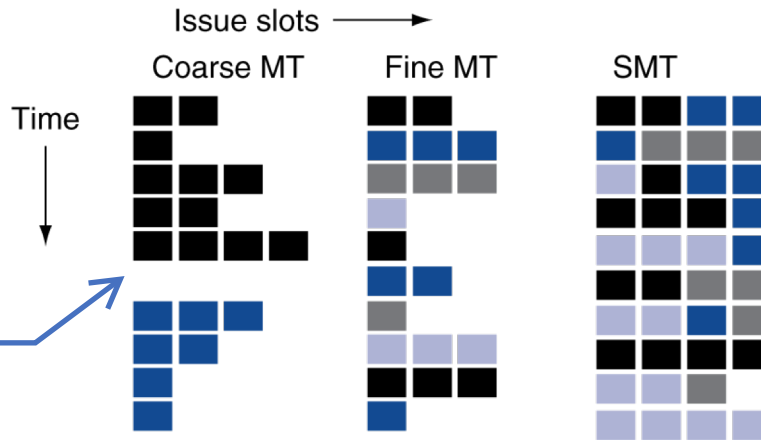
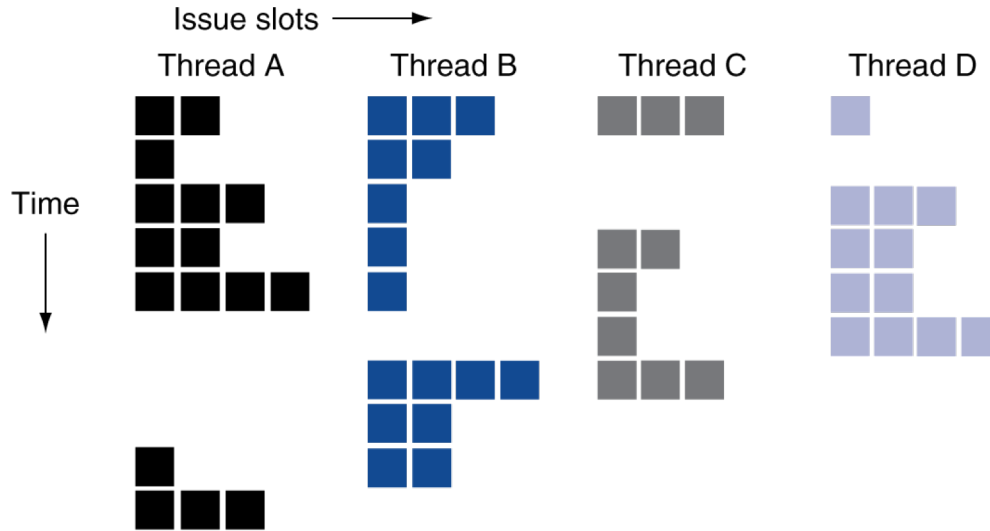

一個Cycle做
Switch Thread

Future of Multithreading

- Will it survive? In what form?
- Power considerations \Rightarrow simplified microarchitectures
 - Simpler forms of multithreading
- Tolerating cache-miss latency
 - Thread switch may be most effective
- Multiple simple cores might share resources more effectively

Shared Memory

- SMP: shared memory multiprocessor
 - Hardware provides single physical address space for all processors
 - Synchronize shared variables using locks
 - Memory access time
 - UMA (uniform) vs. NUMA (nonuniform)

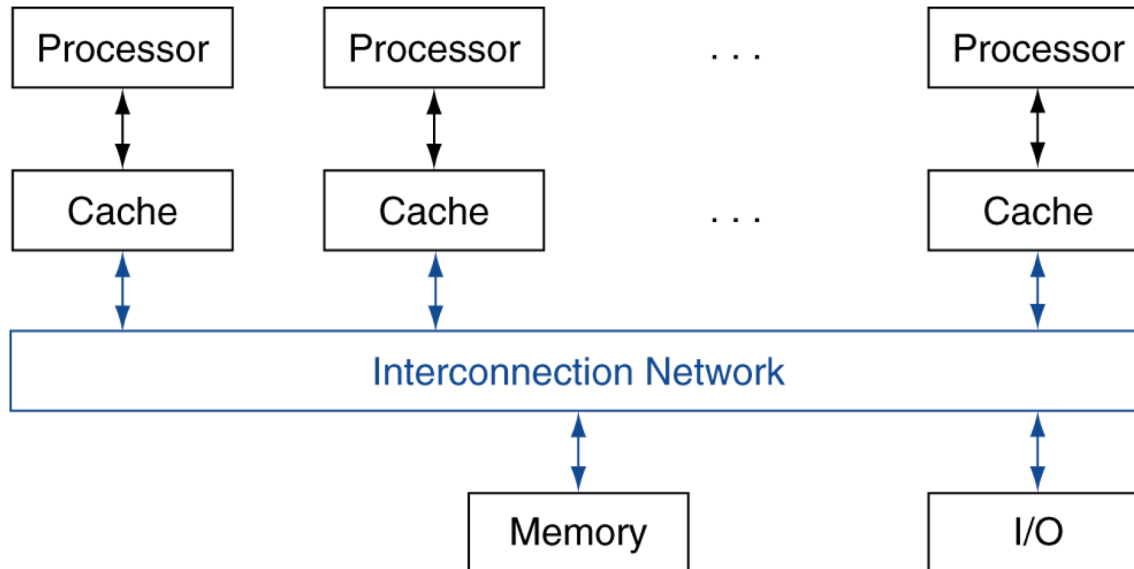

Example: Sum Reduction

- Sum 100,000 numbers on 100 processor UMA
 - Each processor has ID: $0 \leq P_n \leq 99$
 - Partition 1000 numbers per processor
 - Initial summation on each processor

```
sum[Pn] = 0;
for (i = 1000*Pn;
     i < 1000*(Pn+1); i = i + 1)
    sum[Pn] = sum[Pn] + A[i];
```
- Now need to add these partial sums
 - Reduction: divide and conquer
 - Half the processors add pairs, then quarter, ...
 - Need to synchronize between reduction steps

Example: Sum Reduction

```
half = 100;  
repeat
```

```
  synch();
```

```
  if (half%2 != 0 && Pn == 0)
```

```
    sum[0] = sum[0] + sum[half-1];
```

```
    /* Conditional sum needed when half is odd;  
       Processor0 gets missing element */
```

```
  half = half/2; /* dividing line on who sums */
```

```
  if (Pn < half) sum[Pn] = sum[Pn] + sum[Pn+half];
```

```
until (half == 1);
```

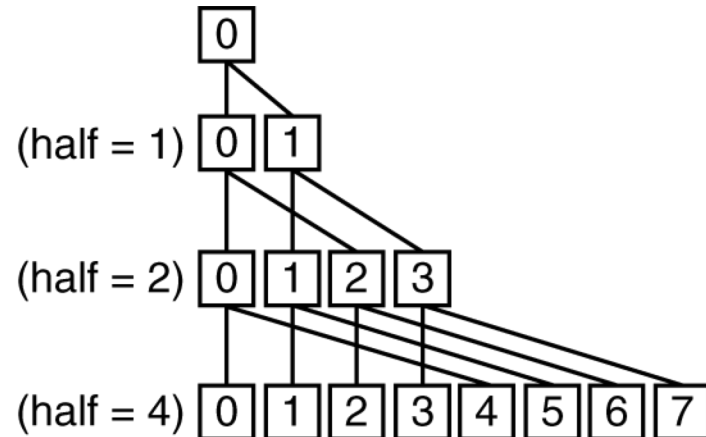

History of GPUs

- Early video cards
 - Frame buffer memory with address generation for video output
- 3D graphics processing
 - Originally high-end computers (e.g., SGI)
 - Moore's Law \Rightarrow lower cost, higher density
 - 3D graphics cards for PCs and game consoles
- Graphics Processing Units
 - Processors oriented to 3D graphics tasks
 - Vertex/pixel processing, shading, texture mapping, rasterization

Graphics in the System

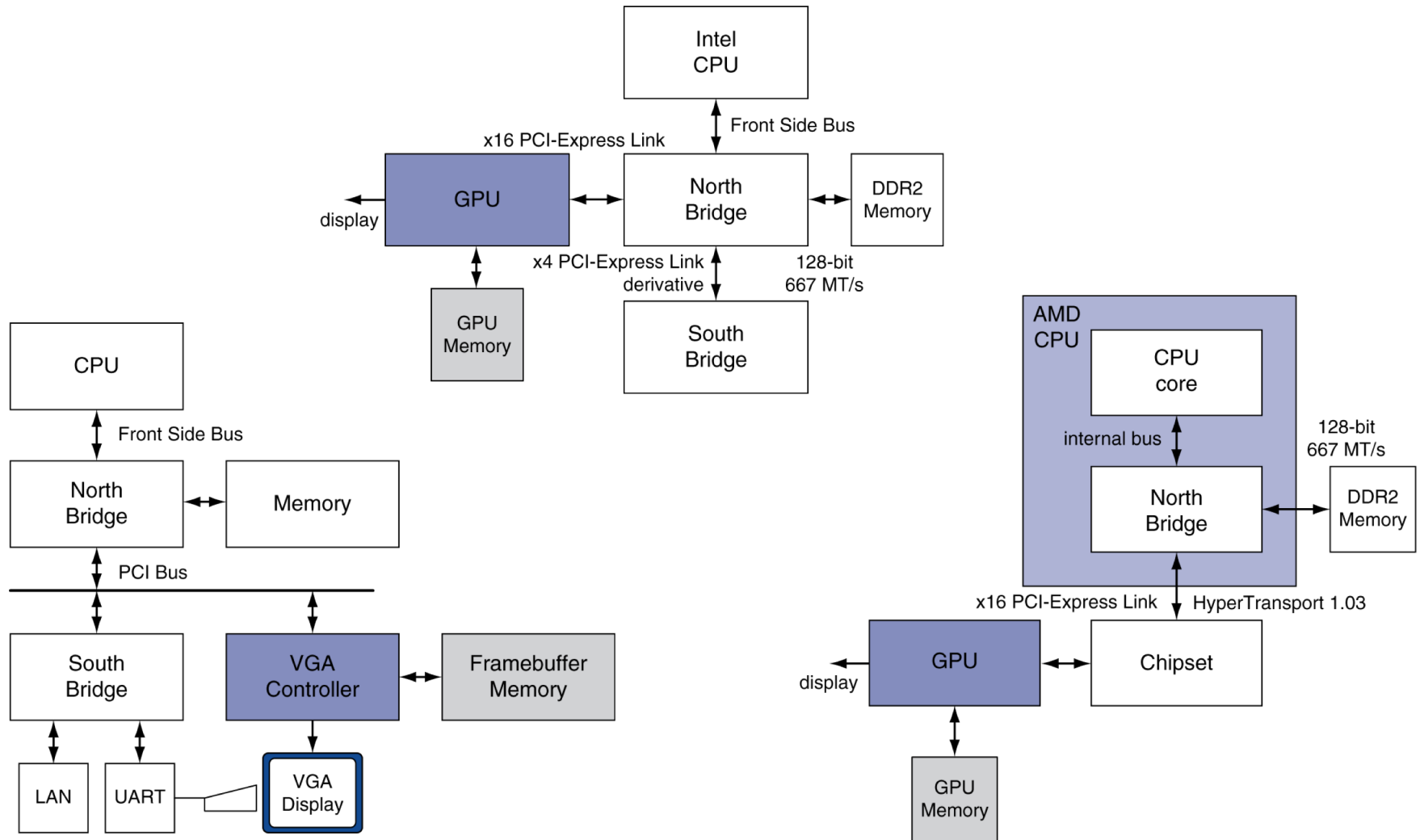

GPU Architectures

- Processing is highly data-parallel
 - GPUs are highly multithreaded
 - Use thread switching to hide memory latency
 - Less reliance on multi-level caches
 - Graphics memory is wide and high-bandwidth
- Trend toward general purpose GPUs
 - Heterogeneous CPU/GPU systems
 - CPU for sequential code, GPU for parallel code
- Programming languages/APIs
 - DirectX, OpenGL
 - C for Graphics (Cg), High Level Shader Language (HLSL)
 - Compute Unified Device Architecture (CUDA)

Example: NVIDIA Tesla

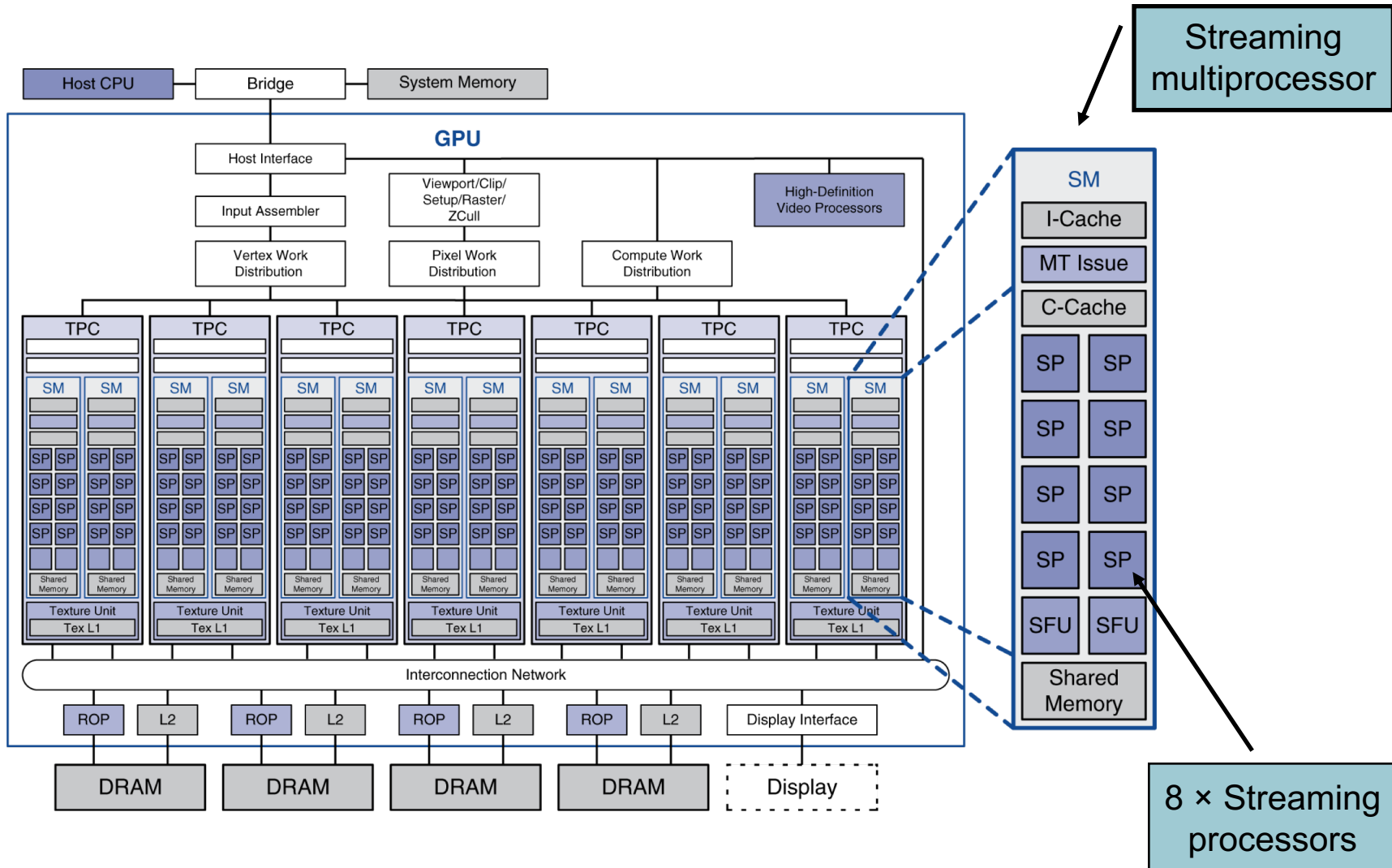

Example: NVIDIA Tesla

- Streaming Processors
 - Single-precision FP and integer units
 - Each SP is fine-grained multithreaded
- Warp: group of 32 threads
 - Executed in parallel, SIMD style
 - 8 SPs
 - × 4 clock cycles
 - Hardware contexts for 24 warps
 - Registers, PCs, ...

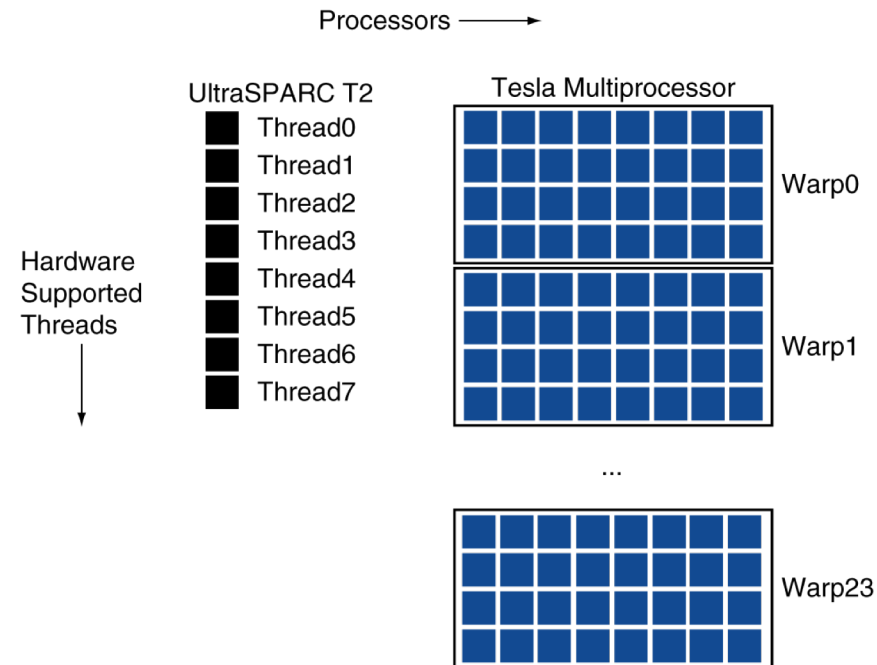

Classifying GPUs

- Don't fit nicely into SIMD/MIMD model
 - Conditional execution in a thread allows an illusion of MIMD
 - But with performance degradation
 - Need to write general purpose code with care

	Static: Discovered at Compile Time	Dynamic: Discovered at Runtime
Instruction-Level Parallelism	VLIW	Superscalar
Data-Level Parallelism	SIMD or Vector	Tesla Multiprocessor

GPU Memory Structures

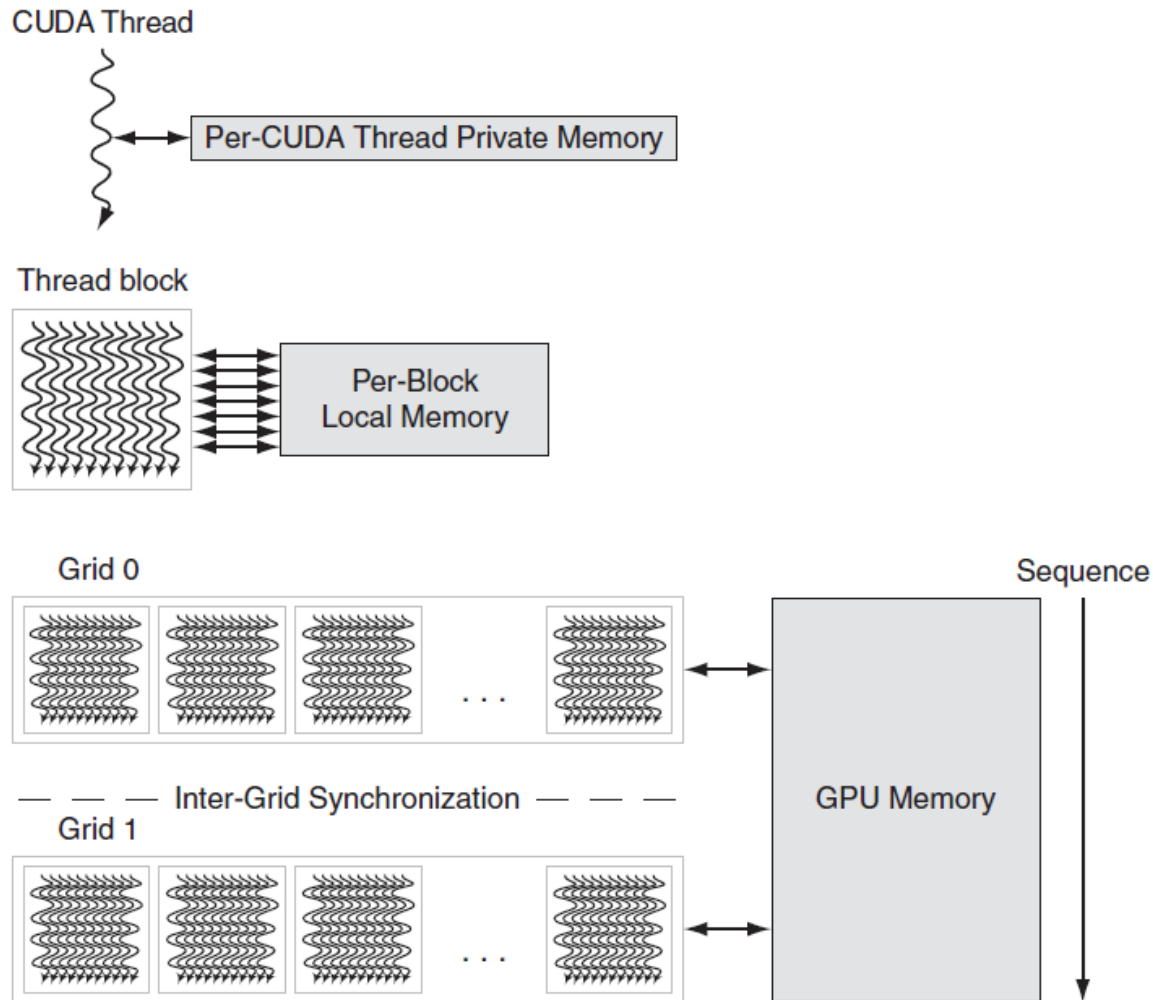

Putting GPUs into Perspective

Feature	Multicore with SIMD	GPU
SIMD processors	4 to 8	8 to 16
SIMD lanes/processor	2 to 4	8 to 16
Multithreading hardware support for SIMD threads	2 to 4	16 to 32
Typical ratio of single precision to double-precision performance	2:1	2:1
Largest cache size	8 MB	0.75 MB
Size of memory address	64-bit	64-bit
Size of main memory	8 GB to 256 GB	4 GB to 6 GB
Memory protection at level of page	Yes	Yes
Demand paging	Yes	No
Integrated scalar processor/SIMD processor	Yes	No
Cache coherent	Yes	No

Type	More descriptive name	Closest old term outside of GPUs	Official CUDA/ NVIDIA GPU term	Book definition
Program abstractions	Vectorizable Loop	Vectorizable Loop	Grid	A vectorizable loop, executed on the GPU, made up of one or more Thread Blocks (bodies of vectorized loop) that can execute in parallel.
	Body of Vectorized Loop	Body of a (Strip-Mined) Vectorized Loop	Thread Block	A vectorized loop executed on a multithreaded SIMD Processor, made up of one or more threads of SIMD instructions. They can communicate via Local Memory.
	Sequence of SIMD Lane Operations	One iteration of a Scalar Loop	CUDA Thread	A vertical cut of a thread of SIMD instructions corresponding to one element executed by one SIMD Lane. Result is stored depending on mask and predicate register.
Machine object	A Thread of SIMD Instructions	Thread of Vector Instructions	Warp	A traditional thread, but it contains just SIMD instructions that are executed on a multithreaded SIMD Processor. Results stored depending on a per-element mask.
	SIMD Instruction	Vector Instruction	PTX Instruction	A single SIMD instruction executed across SIMD Lanes.
Processing hardware	Multithreaded SIMD Processor	(Multithreaded) Vector Processor	Streaming Multiprocessor	A multithreaded SIMD Processor executes threads of SIMD instructions, independent of other SIMD Processors.
	Thread Block Scheduler	Scalar Processor	Giga Thread Engine	Assigns multiple Thread Blocks (bodies of vectorized loop) to multithreaded SIMD Processors.
	SIMD Thread Scheduler	Thread scheduler in a Multithreaded CPU	Warp Scheduler	Hardware unit that schedules and issues threads of SIMD instructions when they are ready to execute; includes a scoreboard to track SIMD Thread execution.
	SIMD Lane	Vector lane	Thread Processor	A SIMD Lane executes the operations in a thread of SIMD instructions on a single element. Results stored depending on mask.
Memory hardware	GPU Memory	Main Memory	Global Memory	DRAM memory accessible by all multithreaded SIMD Processors in a GPU.
	Local Memory	Local Memory	Shared Memory	Fast local SRAM for one multithreaded SIMD Processor, unavailable to other SIMD Processors.
	SIMD Lane Registers	Vector Lane Registers	Thread Processor Registers	Registers in a single SIMD Lane allocated across a full thread block (body of vectorized loop).

Message Passing

- Each processor has private physical address space
- Hardware sends/receives messages between processors

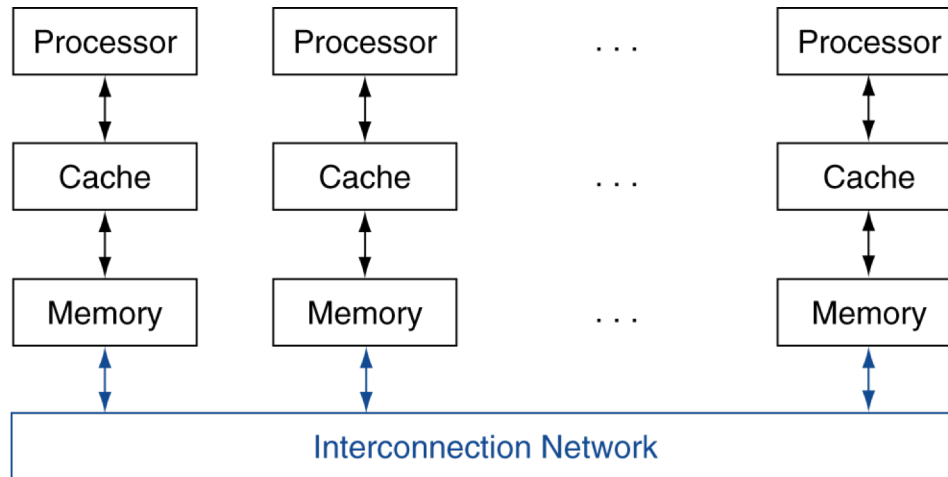

Loosely Coupled Clusters

- Network of independent computers
 - Each has private memory and OS
 - Connected using I/O system
 - E.g., Ethernet/switch, Internet
- Suitable for applications with independent tasks
 - Web servers, databases, simulations, ...
- High availability, scalable, affordable
- Problems
 - Administration cost (prefer virtual machines)
 - Low interconnect bandwidth
 - c.f. processor/memory bandwidth on an SMP

Sum Reduction (Again)

- Sum 100,000 on 100 processors
- First distribute 100 numbers to each
 - They do partial sums

```
sum = 0;
for (i = 0; i < 1000; i = i + 1)
    sum = sum + AN[i];
```
- Reduction
 - Half the processors send, other half receive and add
 - The quarter send, quarter receive and add, ...

Sum Reduction (Again)

- Given send() and receive() operations

```
limit = 100; half = 100; /* 100 processors */
repeat
    half = (half+1)/2; /* send vs. receive
                        dividing line */
    if (Pn >= half && Pn < limit)
        send(Pn - half, sum);
    if (Pn < (limit/2))
        sum = sum + receive();
    limit = half; /* upper limit of senders */
until (half == 1); /* exit with final sum */
```

- Send/receive also provide synchronization
- Assumes send/receive take similar time to addition

Grid Computing

- Separate computers interconnected by long-haul networks
 - E.g., Internet connections
 - Work units farmed out, results sent back
- Can make use of idle time on PCs
 - E.g., SETI@home, World Community Grid

Interconnection Networks

- Network topologies
 - Arrangements of processors, switches, and links



Bus

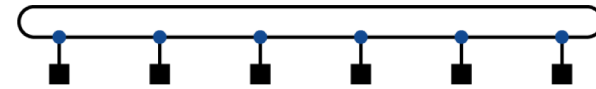

Ring

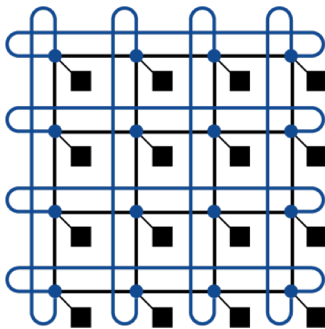

2D Mesh

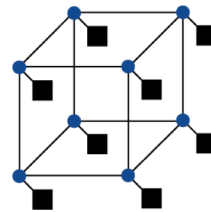

N-cube (N = 3)

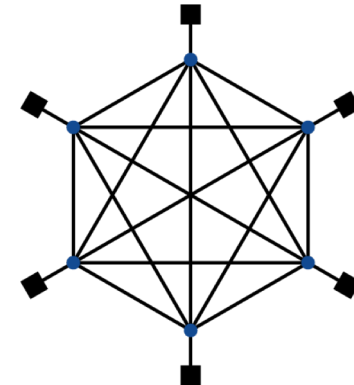

Fully connected

Multistage Networks

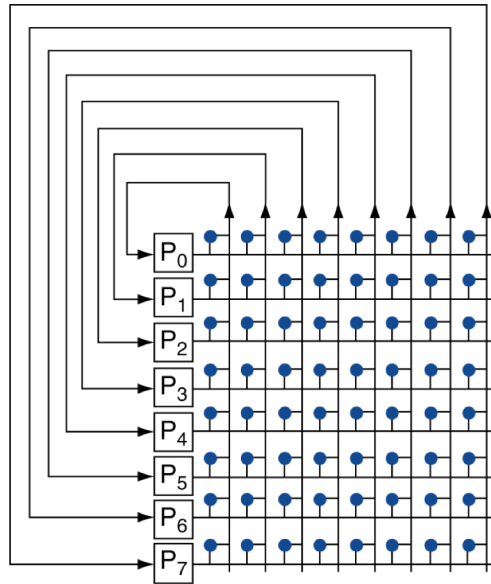

a. Crossbar

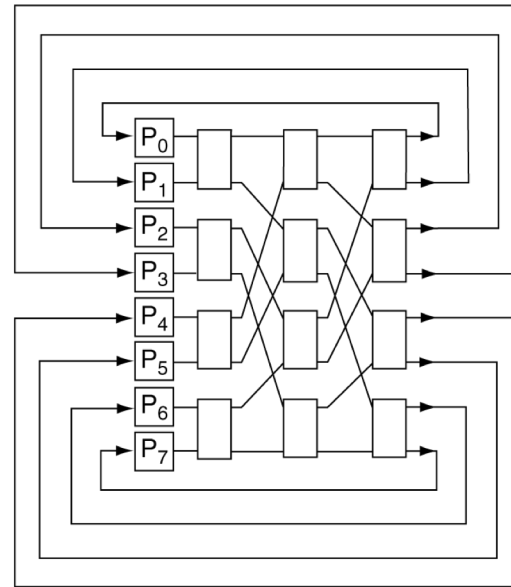

b. Omega network

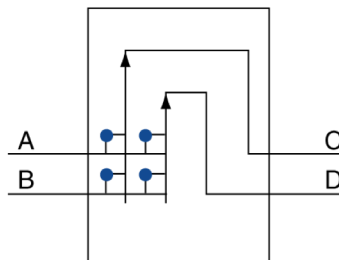

c. Omega network switch box

Network Characteristics

- Performance
 - Latency per message (unloaded network)
 - Throughput
 - Link bandwidth
 - Total network bandwidth
 - Bisection bandwidth
 - Congestion delays (depending on traffic)
- Cost
- Power
- Routability in silicon

Parallel Benchmarks

- Linpack: matrix linear algebra
- SPECrate: parallel run of SPEC CPU programs
 - Job-level parallelism
- SPLASH: Stanford Parallel Applications for Shared Memory
 - Mix of kernels and applications, strong scaling
- NAS (NASA Advanced Supercomputing) suite
 - computational fluid dynamics kernels
- PARSEC (Princeton Application Repository for Shared Memory Computers) suite
 - Multithreaded applications using Pthreads and OpenMP

Code or Applications?

- Traditional benchmarks
 - Fixed code and data sets
- Parallel programming is evolving
 - Should algorithms, programming languages, and tools be part of the system?
 - Compare systems, provided they implement a given application
 - E.g., Linpack, Berkeley Design Patterns
- Would foster innovation in approaches to parallelism

Modeling Performance

- Assume performance metric of interest is achievable GFLOPs/sec
 - Measured using computational kernels from Berkeley Design Patterns
- Arithmetic intensity of a kernel
 - FLOPs per byte of memory accessed
- For a given computer, determine
 - Peak GFLOPS (from data sheet)
 - Peak memory bytes/sec (using Stream benchmark)

Roofline Diagram

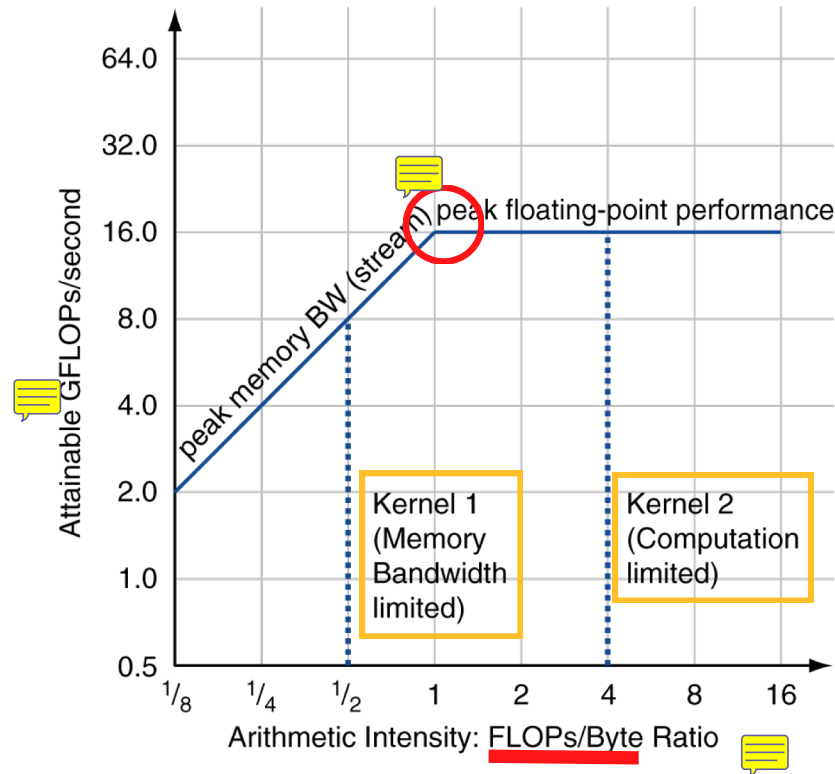

Attainable GPLOPs/sec

= Max (Peak Memory BW × Arithmetic Intensity, Peak FP Performance)

Comparing Systems

- Example: Opteron X2 vs. Opteron X4
 - 2-core vs. 4-core, 2× FP performance/core, 2.2GHz vs. 2.3GHz
 - Same memory system

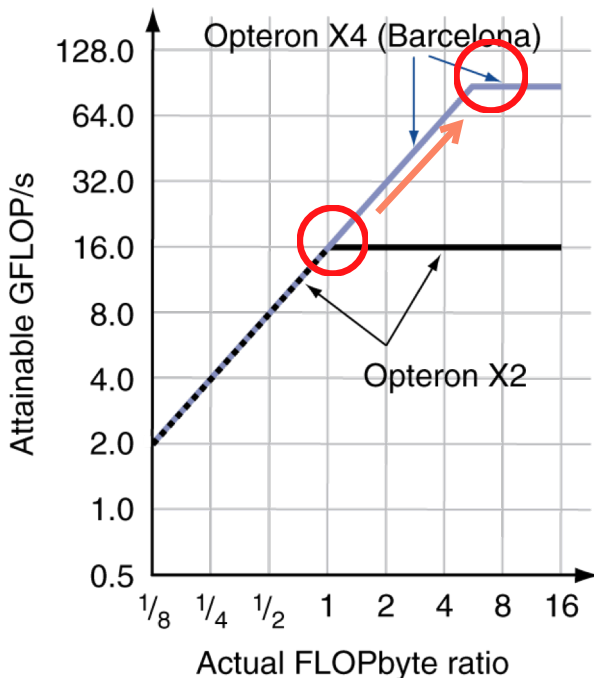

- To get higher performance on X4 than X2
 - Need high arithmetic intensity
 - Or working set must fit in X4's 2MB L-3 cache

Optimizing Performance

- Optimize FP performance
 - Balance adds & multiplies
 - Improve superscalar ILP and use of SIMD instructions

Improve 計算能力的部分(右)

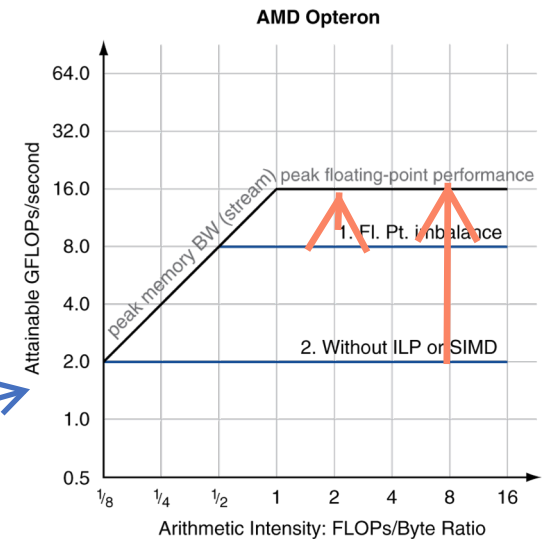

- Optimize memory usage
 - Software prefetch
 - Avoid load stalls
 - Memory affinity
 - Avoid non-local data accesses

Improve 記憶體使用的部分(左)

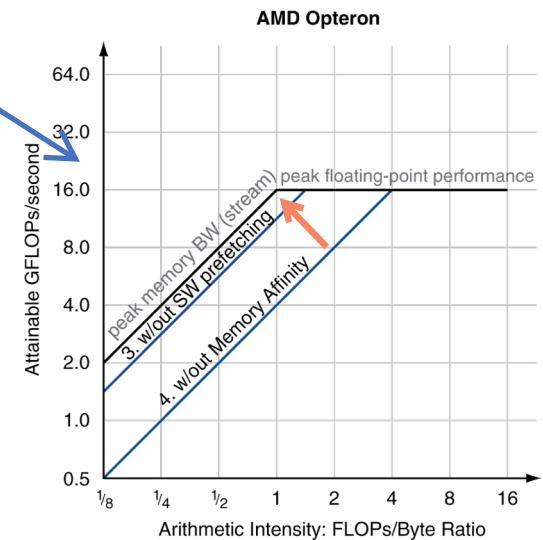

Optimizing Performance

- Choice of optimization depends on arithmetic intensity of code

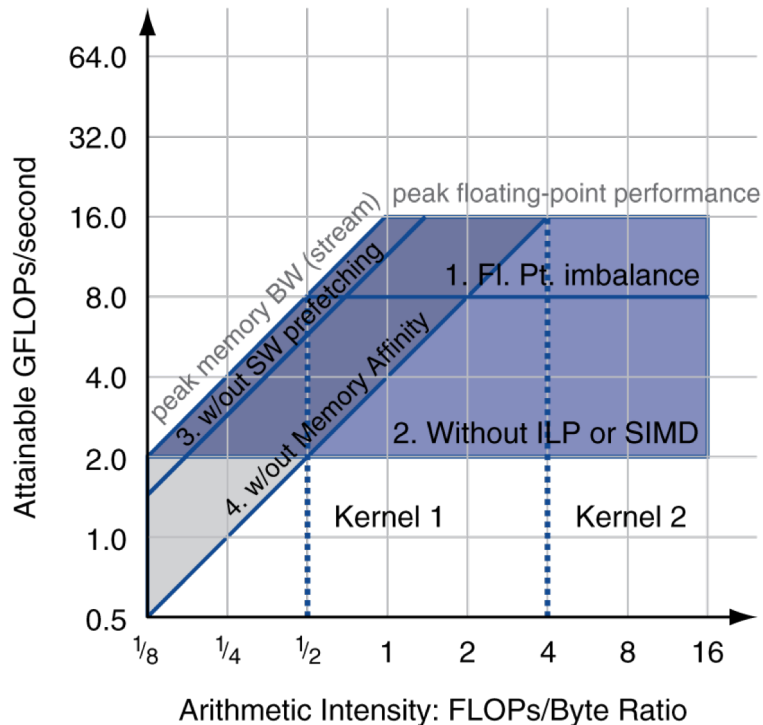

- Arithmetic intensity is not always fixed
 - May scale with problem size
 - Caching reduces memory accesses
 - Increases arithmetic intensity

i7-960 vs. NVIDIA Tesla 280/480

	Core i7-960	GTX 280	GTX 480	Ratio 280/i7	Ratio 480/i7
Number of processing elements (cores or SMs)	4	30	15	7.5	3.8
Clock frequency (GHz)	3.2	1.3	1.4	0.41	0.44
Die size	263	576	520	2.2	2.0
Technology	Intel 45 nm	TCMS 65 nm	TCMS 40 nm	1.6	1.0
Power (chip, not module)	130	130	167	1.0	1.3
Transistors	700 M	1400 M	3100 M	2.0	4.4
Memory bandwidth (GBytes/sec)	32	141	177	4.4	5.5
Single precision SIMD width	4	8	32	2.0	8.0
Double precision SIMD width	2	1	16	0.5	8.0
Peak Single precision scalar FLOPS (GFLOP/sec)	26	117	63	4.6	2.5
Peak Single precision SIMD FLOPS (GFLOP/Sec)	102	311 to 933	515 to 1344	3.0-9.1	6.6-13.1
(SP 1 add or multiply)	N.A.	(311)	(515)	(3.0)	(6.6)
(SP 1 instruction fused)	N.A.	(622)	(1344)	(6.1)	(13.1)
(face SP dual issue fused)	N.A.	(933)	N.A.	(9.1)	-
Peak double precision SIMD FLOPS (GFLOP/sec)	51	78	515	1.5	10.1

Rooflines

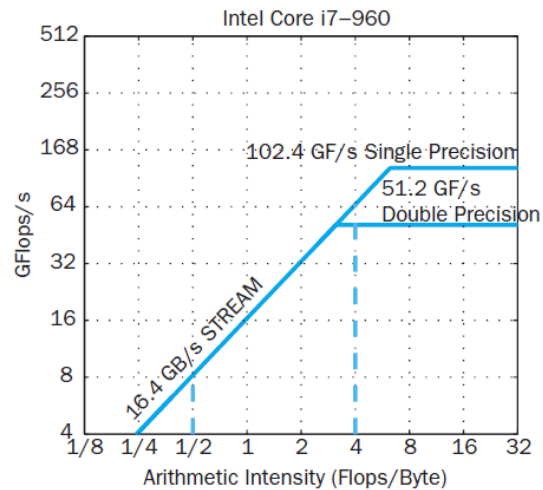
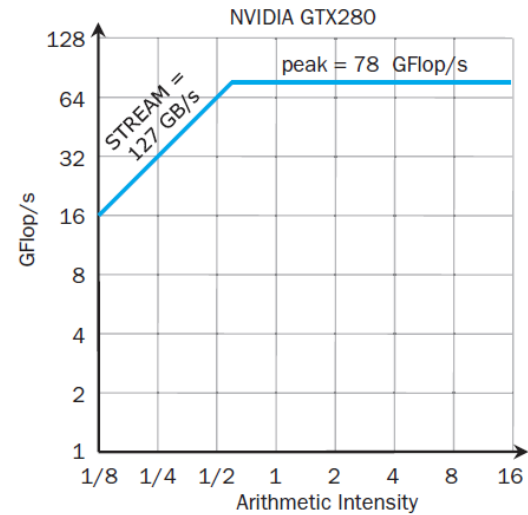
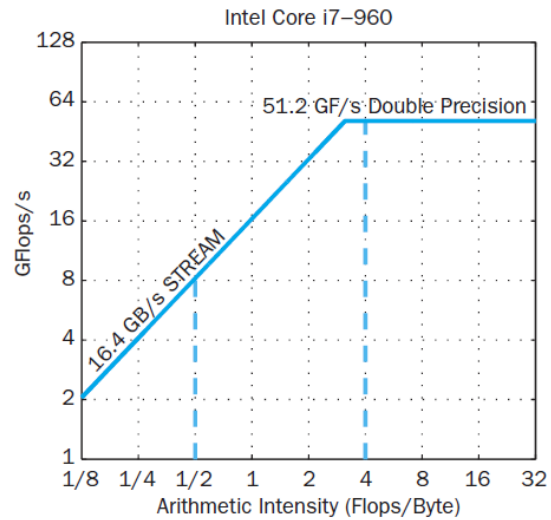

Benchmarks

Kernel	Units	Core i7-960	GTX 280	GTX 280/ i7-960
SGEMM	GFLOP/sec	94	364	3.9
MC	Billion paths/sec	0.8	1.4	1.8
Conv	Million pixels/sec	1250	3500	2.8
FFT	GFLOP/sec	71.4	213	3.0
SAXPY	GBytes/sec	16.8	88.8	5.3
LBM	Million lookups/sec	85	426	5.0
Solv	Frames/sec	103	52	0.5
SpMV	GFLOP/sec	4.9	9.1	1.9
GJK	Frames/sec	67	1020	15.2
Sort	Million elements/sec	250	198	0.8
RC	Frames/sec	5	8.1	1.6
Search	Million queries/sec	50	90	1.8
Hist	Million pixels/sec	1517	2583	1.7
Bilat	Million pixels/sec	83	475	5.7

Performance Summary

- GPU (480) has 4.4 X the memory bandwidth
 - Benefits memory bound kernels
- GPU has 13.1 X the single precision throughput, 2.5 X the double precision throughput
 - Benefits FP compute bound kernels
- CPU cache prevents some kernels from becoming memory bound when they otherwise would on GPU
- GPUs offer scatter-gather, which assists with kernels with strided data
- Lack of synchronization and memory consistency support on GPU limits performance for some kernels

Multi-threading DGEMM

- Use OpenMP:

```
void dgemm (int n, double* A, double* B, double* C)
{
#pragma omp parallel for
  for ( int sj = 0; sj < n; sj += BLOCKSIZE )
    for ( int si = 0; si < n; si += BLOCKSIZE )
      for ( int sk = 0; sk < n; sk += BLOCKSIZE )
        do_block(n, si, sj, sk, A, B, C);
}
```

Multithreaded DGEMM

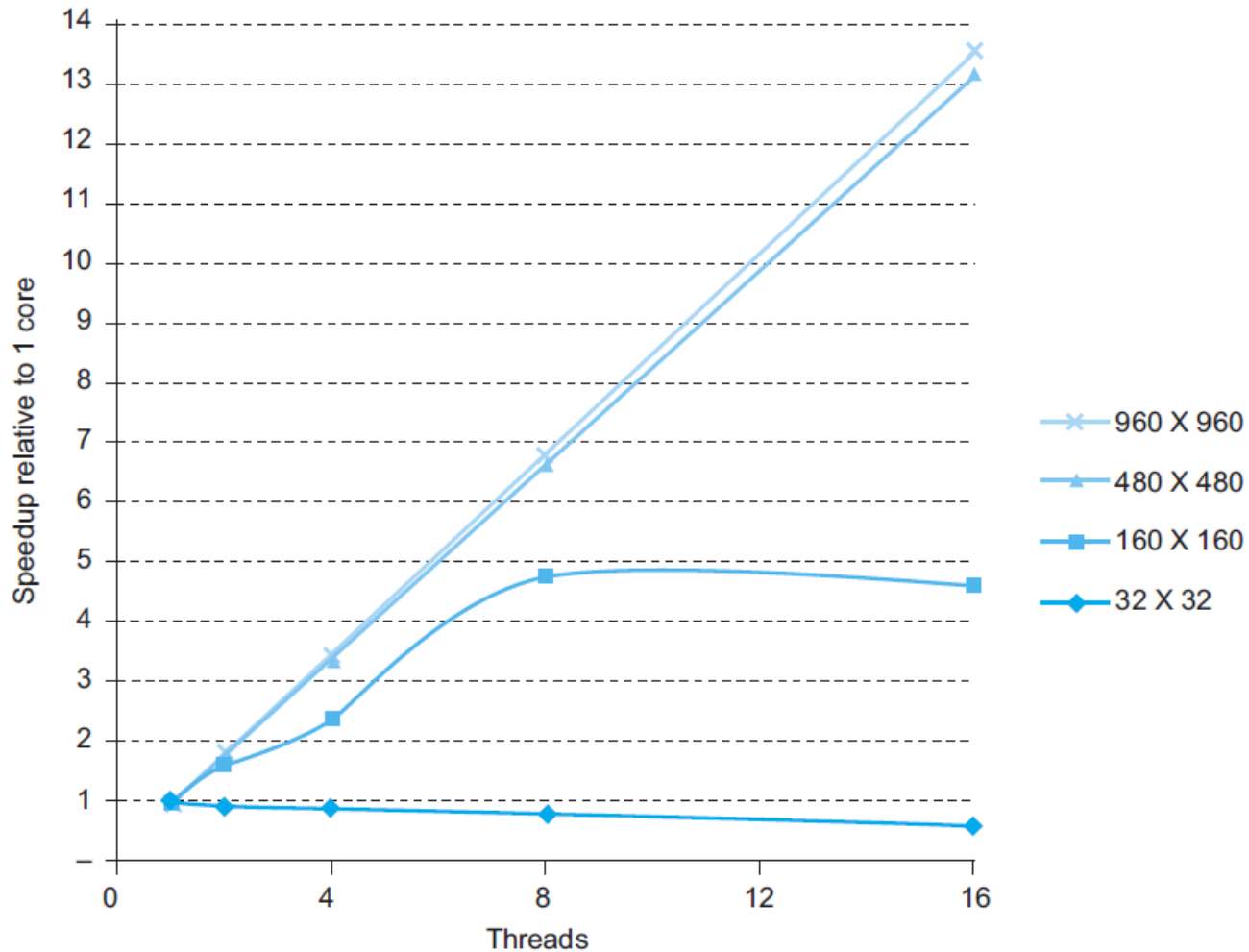

Multithreaded DGEMM

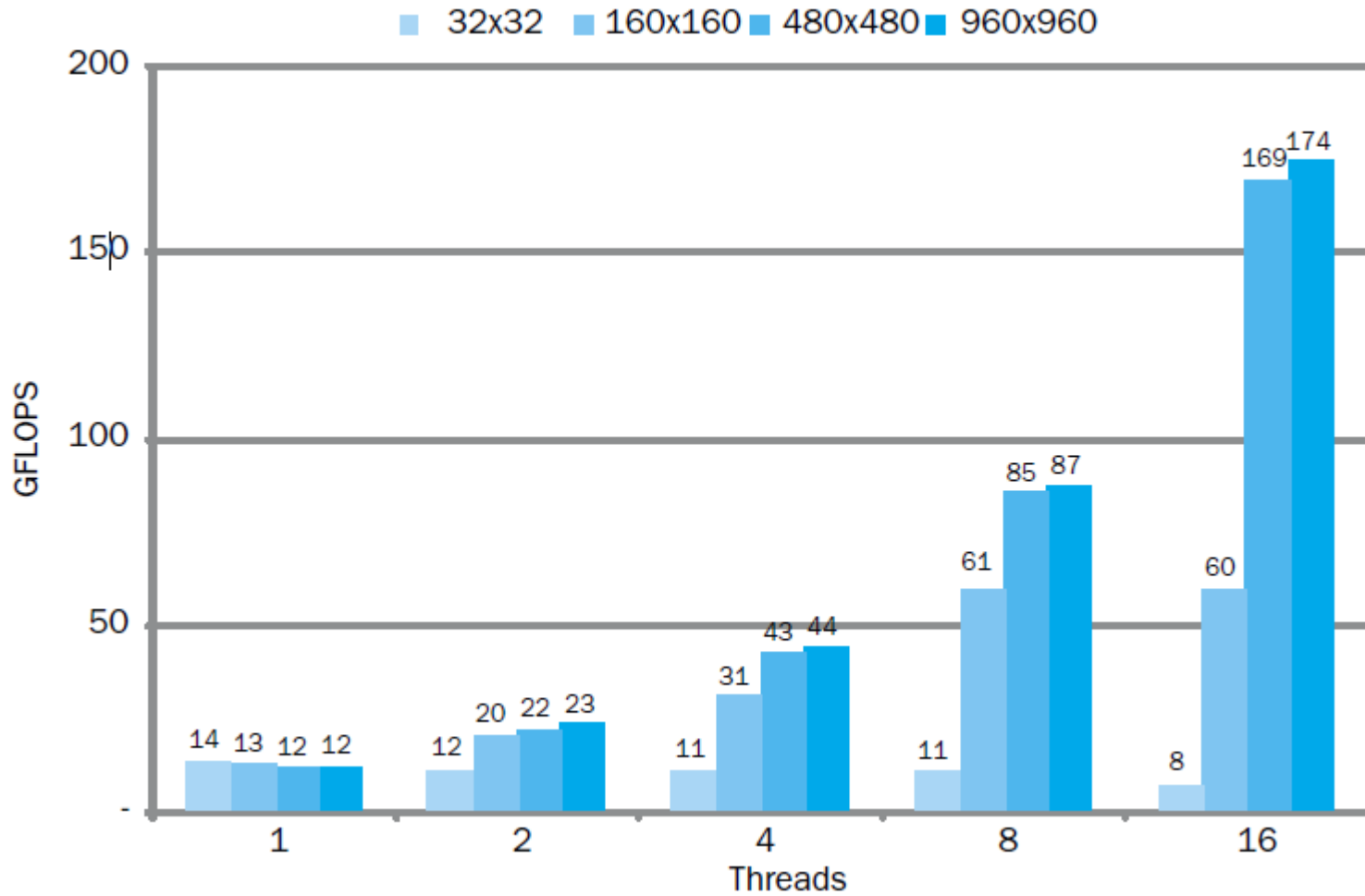

Fallacies

- Amdahl's Law doesn't apply to parallel computers
 - Since we can achieve linear speedup
 - But only on applications with weak scaling
- Peak performance tracks observed performance
 - Marketers like this approach!
 - But compare Xeon with others in example
 - Need to be aware of bottlenecks

Pitfalls

- Not developing the software to take account of a multiprocessor architecture
 - Example: using a single lock for a shared composite resource
 - Serializes accesses, even if they could be done in parallel
 - Use finer-granularity locking

Concluding Remarks

- Goal: higher performance by using multiple processors
- Difficulties
 - Developing parallel software
 - Devising appropriate architectures
- SaaS importance is growing and clusters are a good match
- Performance per dollar and performance per Joule drive both mobile and WSC

Concluding Remarks (con't)

- SIMD and vector operations match multimedia applications and are easy to program

